

P 90
1 / 3 - 1 / 4

P 90 + MOTORIDUTTORE MU 110
P 90 + WORMGEARED MOTOR MU 110
P 90 + GETRIEBEMOTOR MU 110

Albero lento
Output shaft
Abtriebswelle
D = 42 mm

MU 110

i	i ₁	i ₂	n ₁	n ₂	M ₂ (Nm)	kW ₁	HP ₁	RD
75,0	3	25	2800	37,3	680	3,37	4,58	0,789
90,0	3	30		31,1	770	3,27	4,45	0,766
120,0	3	40		23,3	799	2,71	3,69	0,720
150,0	3	50		18,7	695	1,97	2,68	0,689
180,0	3	60		15,6	663	1,63	2,22	0,663
200,0	4	50		14,0	695	1,48	2,01	0,689
210,0	3	70		13,3	629	1,43	1,95	0,614
240,0	3	80		11,7	585	1,17	1,59	0,613
300,0	3	100		9,3	633	1,10	1,49	0,564
320,0	4	80		8,8	585	0,87	1,19	0,613
400,0	4	100	7,0	633	0,82	1,12	0,564	

i	i ₁	i ₂	n ₁	n ₂	M ₂ (Nm)	kW ₁	HP ₁	sf
75,0	3	25	2800	37,3	444	2,20	3,00	1,53
90,0	3	30		31,1	517	2,20	3,00	1,49
120,0	3	40		23,3	648	2,20	3,00	1,23
150,0	3	50		18,7	775	2,20	3,00	0,90
180,0	3	60		15,6	610	1,50	2,00	1,09
200,0	4	50		14,0	705	1,50	2,00	0,99
210,0	3	70		13,3	660	1,50	2,00	0,95
240,0	3	80		11,7	753	1,50	2,00	0,78
300,0	3	100		9,3	865	1,50	2,00	0,73
320,0	4	80		8,8	1004	1,50	2,00	0,58
400,0	4	100	7,0	1153	1,50	2,00	0,55	

75,0	3	25	1400	18,7	780	2,10	2,85	0,728
90,0	3	30		15,6	881	2,00	2,72	0,718
120,0	3	40		11,7	902	1,65	2,25	0,667
150,0	3	50		9,3	790	1,26	1,72	0,612
180,0	3	60		7,8	739	1,05	1,43	0,573
200,0	4	50		7,0	790	0,95	1,29	0,612
210,0	3	70		6,7	701	0,90	1,22	0,544
240,0	3	80		5,8	659	0,78	1,06	0,517
300,0	3	100		4,7	768	0,80	1,08	0,471
320,0	4	80		4,4	659	0,58	0,79	0,517
400,0	4	100	3,5	768	0,60	0,81	0,471	

75,0	3	25	1400	18,7	558	1,50	2,00	1,40
90,0	3	30		15,6	661	1,50	2,00	1,33
120,0	3	40		11,7	819	1,50	2,00	1,10
150,0	3	50		9,3	939	1,50	2,00	0,84
180,0	3	60		7,8	774	1,10	1,50	0,95
200,0	4	50		7,0	919	1,10	1,50	0,86
210,0	3	70		6,7	857	1,10	1,50	0,82
240,0	3	80		5,8	931	1,10	1,50	0,71
300,0	3	100		4,7	1061	1,10	1,50	0,72
320,0	4	80		4,4	1241	1,10	1,50	0,53
400,0	4	100	3,5	1415	1,10	1,50	0,54	

75,0	3	25	900	12,0	782	1,35	1,84	0,728
90,0	3	30		10,0	884	1,30	1,77	0,713
120,0	3	40		7,5	905	1,07	1,45	0,664
150,0	3	50		6,0	793	0,78	1,07	0,635
180,0	3	60		5,0	744	0,66	0,90	0,592
200,0	4	50		4,5	793	0,59	0,80	0,635
210,0	3	70		4,3	703	0,58	0,79	0,544
240,0	3	80		3,8	663	0,48	0,65	0,542
300,0	3	100		3,0	771	0,51	0,70	0,471
320,0	4	80		2,8	663	0,36	0,49	0,542
400,0	4	100	2,3	771	0,39	0,52	0,471	

75,0	3	25	900	12,0	637	1,10	1,50	1,23
90,0	3	30		10,0	749	1,10	1,50	1,18
120,0	3	40		7,5	931	1,10	1,50	0,97
150,0	3	50		6,0	758	0,75	1,00	1,05
180,0	3	60		5,0	848	0,75	1,00	0,88
200,0	4	50		4,5	1011	0,75	1,00	0,78
210,0	3	70		4,3	909	0,75	1,00	0,77
240,0	3	80		3,8	1036	0,75	1,00	0,64
300,0	3	100		3,0	1126	0,75	1,00	0,69
320,0	4	80		2,8	1381	0,75	1,00	0,48
400,0	4	100	2,3	1501	0,75	1,00	0,51	

P 90 - MU 110

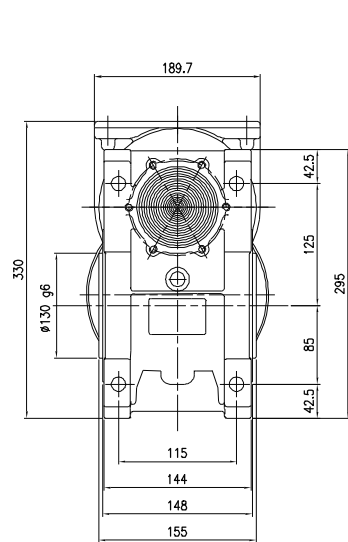

FLANGIA ATTACCO MOTORE GRANDEZZA 90 B14 (24/140)

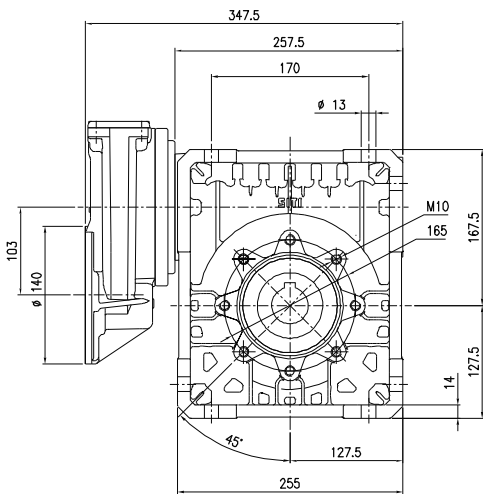

MOTOR COUPLING FLANGE, SIZE 90 B14 (24/140)

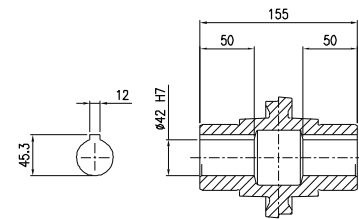

FLANSCH ANSCHLUSS MOTOR GRÖSSE 90 B14 (24/140)