

# SITI

SPA

SOCIETÀ ITALIANA TRASMISSIONI INDUSTRIALI



PL-MPL / PD-MPD

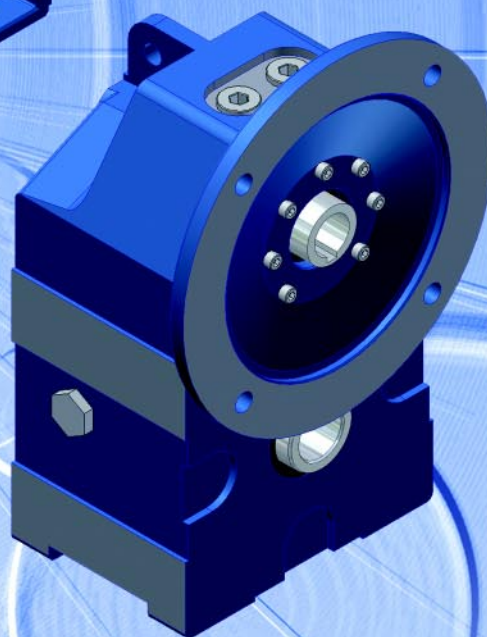
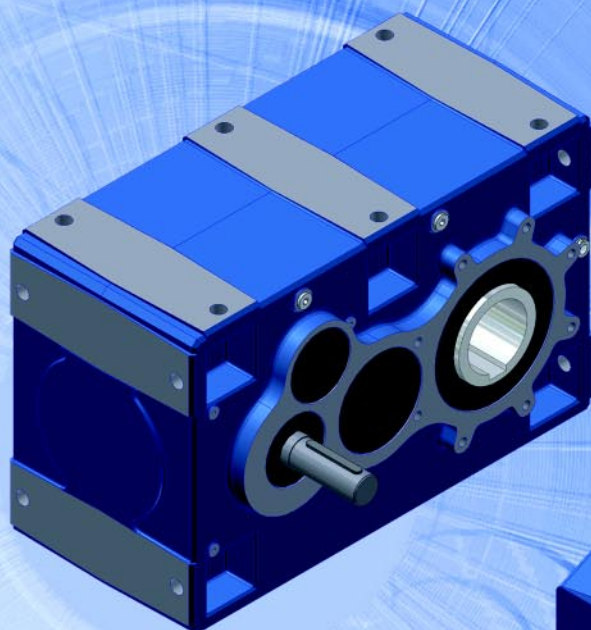

**CATALOGO TECNICO - COMMERCIALE**



**TECHNICAL & COMMERCIAL CATALOGUE**



**TECHNISCHER HANDELSKATALOG**

**03.2008**



SITI S.p.A. La ringrazia per la fiducia accordata e Le ricorda che il Suo riduttore è il risultato di un lavoro di miglioramento del prodotto che i nostri tecnici perseguono continuamente, grazie ad una ricerca costante nel settore.

La rete di Assistenza è a Sua disposizione per aiutarLa a risolvere dubbi che potessero sorgere nella lettura di questa pubblicazione.

E' vietata la riproduzione, la memorizzazione o l'alterazione, anche parziale, di questa pubblicazione, senza una autorizzazione scritta da parte della SITI S.p.A.

**We, at SITI S.p.A., would like to thank you for the confidence shown in choosing our products. Our dedication to quality and innovation has allowed us to develop highly efficient gearboxes able to fulfil even the most demanding requirements.**

**If, in case of any doubt, please do not hesitate to contact our Customer Service Department or Service centers for more detailed information.**

**Copyright. The contents of the manual and drawings are valuable trade secrets and must not be given to third parties, copied, reproduced, disclosed or transferred unless duly authorized by SITI S.p.A. in writing in advance.**

*Die Firma SITI bedankt sich für das geschenkte Vertrauen und möchte Sie darauf aufmerksam machen, dass das Untersetzungsgetriebe das Ergebnis einer langen Verbesserungsarbeit sowie einer konstanten Forschung in diesem Bereich darstellt.*

*Der Kundendienst steht gern zu Ihrer Verfügung, um eventuelle Zweifel, die beim Lesen dieser Veröffentlichung aufsteigen können, zu beseitigen.*

*Es ist verboten, diese Unterlage ohne die schriftliche Genehmigung der Firma SITI S.p.A. zu vervielfältigen, elektronisch zu speichern oder auch teilweise zu modifizieren.*

## DATI DI IDENTIFICAZIONE DEL COSTRUTTORE

 SOCIETÀ ITALIANA TRASMISSIONI INDUSTRIALI ® RIDUTTORI MOTORIDUTTORI VARIATORI CONTINUI MOTORI ELETTRICI C.A./C.C. GIUNTI ELASTICI
<hr/> <b>SEDE e STABILIMENTO</b> Via G. Di Vittorio, 4 40050 Monteveglio - BO - Italy Tel. +39/051/6714811 Fax. +39/051/6714858 E-mail: <a href="mailto:info@sitiriduttori.it">info@sitiriduttori.it</a> WebSite: <a href="http://www.sitiriduttori.it">www.sitiriduttori.it</a>

## MANUFACTURER'S DATA

 SOCIETÀ ITALIANA TRASMISSIONI INDUSTRIALI ® GEARBOXES GEARED MOTORS SPEED VARIATORS A.C./D.C. ELECTRIC MOTORS FLEXIBLE COUPLINGS
<hr/> <b>HEADQUARTER</b> Via G. Di Vittorio, 4 40050 Monteveglio - BO - Italy Tel. +39/051/6714811 Fax. +39/051/6714858 E-mail: <a href="mailto:info@sitiriduttori.it">info@sitiriduttori.it</a> WebSite: <a href="http://www.sitiriduttori.it">www.sitiriduttori.it</a>

## KENNZEICHNUNGSDATEN DES HERSTELLERS

 SOCIETÀ ITALIANA TRASMISSIONI INDUSTRIALI ® GETRIEBE GETRIEBEMOTOREN VERSTELLGETRIEBE WECHSEL- UND GLEICHSTROM MOTOREN ELASTISCHE KUPPLUNGEN
<hr/> <b>SITZ UND BETRIEB</b> Via G. Di Vittorio, 4 40050 Monteveglio - BO - Italy Tel. +39/051/6714811 Fax. +39/051/6714858 E-mail: <a href="mailto:info@sitiriduttori.it">info@sitiriduttori.it</a> WebSite: <a href="http://www.sitiriduttori.it">www.sitiriduttori.it</a>

La SITI S.p.A. si riserva il diritto di apportare senza preavviso modifiche alle caratteristiche tecniche ed agli accessori dei prodotti contenuti in questo catalogo.

**SITI S.p.A. reserves the right to modify without notice the technical features and the accessories of the products contained in this catalogue.**

*SITI S.p.A. ist erlaubt, Änderungen den technischen Merkmalen sowohl den Zubehöeren durchzuführen, die in diesem Katalog vorliegend sind.*



## CARATTERISTICHE TECNICHE

### PREMESSA

Il presente catalogo è relativo ai riduttori ad assi paralleli serie PL-MPL ed ai riduttori pendolari serie PD-MPD, costruiti dalla SITI SpA. I riduttori delle serie PL-MPL e PD-MPD hanno il corpo in ghisa G25 e sono dotati di rotismi a due o tre stadi di riduzione.

### CARATTERISTICHE COSTRUTTIVE

- Riduttori dotati di rotismi a due o a tre stadi di riduzione.
- Nei riduttori PL e PD, sia la prima che la seconda riduzione sono realizzate con ingranaggi cilindrici a denti elicoidali con profili accuratamente corretti. Il terzo stadio di riduzione è ottenuto aggiungendo a monte (entrata riduttore) un ulteriore stadio di riduzione formato da due ingranaggi cilindrici con dentatura corretta.
- Sono realizzati in 5 grandezze: 63 – 80 – 100 – 125 – 160 (il numero che definisce la grandezza rappresenta l'interasse della riduzione finale seconda la serie di Renard R 10).
- Le coppie nominali trasmissibili sono comprese fra 100 Nm. e 4015 Nm.
- La capacità di carico delle dentature è stata verificata secondo le norme DIN 3990, UNI 8862, AGMA 2001 B 88 ed il progetto ISO 6336, con calcolo della resistenza sia al pittino che a flessione al piede del dente, per una durata nominale accuratamente bilanciata ed estremamente elevata.
- Tutti gli ingranaggi sono costruiti in acciaio da cementazione (20 Mn Cr 5 o materiali di equivalente resistenza e temprabilità), e sottoposti a cementazione, tempra e distensione per elevata resistenza alle sollecitazioni statiche e dinamiche e all'usura.
- Gli alberi lenti cavi (soluzione standard) sono costruiti in ghisa sferoidale GS-400.
- Gli alberi lenti pieni, semplici o doppi (soluzione optional) sono costruiti in acciaio da bonifica 42 Cr Mo 4, o materiali di similproprietà.
- Le carcasse sono costruite in ghisa G 25 secondo UNI 5007.

## TECHNICAL FEATURES

### INTRODUCTION

This catalogue relates to parallel shaft gearboxes PL-MPL series and to shaft mounted helical PD-MPD series, manufactured by SITI SpA.

The PL-MPL and PD-MPD series gearboxes have a G25 cast iron housing and are fitted with two or three stage of reduction gears.

### MANUFACTURING FEATURES

- Gearboxes provides with trains of gears at 2 or 3 stages of reduction.
- In the PL and PD gearboxes, the first and second stages of reduction are performed with helical toothed cylindrical gears with accurately corrected profiles. The third reduction stage is achieved by adding a further reduction stage upstream (gearbox input) consisting of two cylindrical gears with corrected tothing.
- They are manufactured in 5 sizes: 63 – 80 – 100 – 125 – 160 (the number relevant to gearbox size means the center-to-center distance of the final reduction stage according to the Renard series R10).
- The rated transmissible torques are included in the range from 100 Nm. to 4015 Nm.
- Load capacities of tothing comply with DIN 3990, UNI 8862, AGMA 2001 B88 norms and the ISO 6336 draft proposal, both with the surface pitting resistance and the tooth root bending strength calculation, in view of an accurately balances and extremely high nominal life.
- All gears are made in case-hardening steel (20 Mn Cr 5 or materials of equivalent strength and hardenability) and are submitted to case-hardening, quenching and stress-relieving, to give high resistance to static and dynamic stresses and to wear.
- Hollow output shafts (standard solution) are manufactured in nodular cast iron GS-400.
- The solid output shafts, with single or double extension (optional solution) are made in hardening and tempering steel 42 Cr Mo 4, or materials of similar properties.
- Housings are made in cast iron G 25 according to UNI 5007 specification.

## TECHNISCHE BESCHREIBUNG

### VORWORT

Dieser Katalog beschreibt die **Stirnradgetriebe der Baureihe PL-MPL** und die **Aufsteckgetriebe der Baureihe PD-MPD** von SITI SpA. Die Getriebe der Baureihen **PL-MPL** und **PD-MPD** besitzen ein Gehäuse aus Gusseisen G25 und sind in zwei- oder dreistufiger Ausführung gebaut.

### BAUEIGENSCHAFTEN

- Für diese Getriebe sind zwei oder drei Untersetzungsstufen vorgesehen.
- Bei den Getrieben PL und PD bestehen die erste und die zweite Stufe aus zylindrischen Zahnradern mit Schrägverzahnung und korrigierten Profilen. Die dritte Stufe ist durch Vorschaltung (Getriebeeingang) einer weiteren Übersetzungsstufe, bestehend aus zwei zylindrischen Zahnradern mit korrigierter Verzahnung erzeugt.
- Die neuen Getriebe werden in fünf Größen gefertigt: 63 – 80 – 100 – 125 – 160 (Die Größe ist nach dem Achsabstand der Abtriebsstufe definiert; Renard R10).
- Die Abtriebsdrehmomente reichen von 100 bis 4015 Nm.
- Die spezifische Zahnbelastung ist nach DIN 3990, UNI 8862, AGMA 2001 B88 und dem Entwurf ISO 6336 festgelegt und dient der Berechnung der Festigkeit in Bezug auf Pitting und Biegefestigkeit im Zahngrund für eine ausgewogene, normal lange Lebensdauer.
- Alle Zahnäder sind aus Einsatzstahl gefertigt (20 Mn Cr 5 oder in Bezug auf Härte und Festigkeit ähnliche Werkstoffe). Um eine höhere Verschleißfestigkeit sowie höhere statische und dynamische Beanspruchungen zu ermöglichen, werden die Zahnäder einsatzgehärtet und spannungsfrei geölt.
- Die Abtriebshohlwellen werden in der Standardausführung aus Sferoguß GS-400 gefertigt.
- Die auf Wunsch lieferbaren, einseitigen und zweiseitigen Abtriebsvollwellen sind aus Stahl 42 Cr Mo 4 oder aus einem vergleichbaren Werkstoff hergestellt.
- Das Gehäuse wird aus G 25 (Guss) nach UNI 5007 gefertigt.

- Tutti i riduttori offrono la possibilità di accettare elevati carichi esterni, sia radiali che assiali, comunque orientati: le nostre tabelle forniscono i valori applicabili senza problemi in tutte le condizioni, per casi speciali sarà comunque possibile valutare l'eventuale idoneità con calcolo specifico.
- **All the gearboxes offer a chance to accept high external loads, both radial and axial ones, wherever oriented: our tables give the ratings which can be applied with no troubles in any condition, for special application purposes it is however advisable to evaluate the possible suitability through a specific calculation.**
- *Alle Getriebe haben den Vorteil, daß höhere radiale und axiale Belastungen übertragen werden können. Bei den in unseren Tabellen angegebenen Daten handelt sich um Standardangaben für allgemeine Anwendungen in sonderfällen können auf Wunsch projektspezifische Berechnungen durchgeführt werden.*
- I rendimenti dinamici sono molto elevati; 0.96 nelle versioni a due stadi e 0.92 nelle versioni a tre stadi.
- **Dynamic efficiencies are very high: 0.96 in the two stage reduction versions and 0.92 in the three stage reduction versions.**
- *Der dynamische Wirkungsgrad dieser Getriebe ist sehr hoch: 0,96 bei den zweistufigen und 0,92 bei den dreistufigen Getrieben.*
- E' possibile operare in condizioni di esercizio particolarmente severe garantendo ancora delle durate soddisfacenti; a questo proposito, raccomandiamo di riferirsi scrupolosamente alle indicazioni dei nostri cataloghi tecnici e, nei casi dubbi, riteniamo indispensabile interpellare il nostro servizio tecnico.
- **It is allowed to operate in particularly severe conditions of application, still saving sufficiently satisfactory life times; in connection with this, we recommend to strictly adhere to the indications of our technical catalogue and, if in doubt, to contact our technical dept.**
- *Es ist möglich diese neue Getriebe auch bei anspruchsvollen Einsatzfällen zu verwenden und eine befriedigende Lebensdauer zu erzielen. Deshalb ist es ratsam, nach den Katalogangaben zu richten und bei auftretenden Unsicherheiten mit unserem technischen Büro Rücksprache zu nehmen.*



## PECULIARITÀ COSTRUTTIVE

- Elevata compattezza ed estrema versatilità di impiego
- Modularità costruttiva, che consente agevoli modifiche della posizione di installazione e montaggio
- Carcassa principale monoblocco ed ulteriore carcassa per ospitare lo stadio di riduzione addizionale (precoppia), facilmente installabile e collegabile alla carcassa principale, utilizzata anche per le versioni PAM a due stadi
- Struttura robusta e resistente, in grado di accettare motori di notevole grandezza e di trasmettere momenti torcenti, sia nominali che di spunto, molto elevati
- Impiego di motori normalizzati, calettati direttamente sull'estremità cava dell'albero veloce
- Elevata capacità di olio per una lubrificazione ottimale
- Elevate capacità di scambio termico, con possibilità di operare anche in condizioni di servizio particolarmente gravose
- Valori contenuti di rumorosità e ridotte possibilità di innesco di vibrazioni in virtù del tipo di costruzione e di montaggio modulare, che minimizza il rischio di montaggio mal eseguito e di allineamenti scorretti
- Livello di qualità più affidabile e ripetitivo del prodotto assemblato
- Ridotte necessità di manutenzione

## LUBRIFICAZIONE

Tutti i riduttori PL e PD provvisti di precoppia (PL../3, e PD../3) vengono da noi forniti con la precoppia già lubrificata e quindi non richiedono alcun riempimento da parte dei clienti. Viene utilizzato l'olio minerale tipo ISO VG 220 (vedi tabella 1). I riduttori PL e PD a due stadi di riduzione, così come la carcassa principale nei riduttori con precoppia vengono invece forniti privi di olio, e la relativa lubrificazione è a cura dei clienti.

## CONSTRUCTION PECULIARITIES

- **High compactness and extreme versatility of usage**
- **Modular construction, enabling easy changes in the installation and assembling positions**
- **Main monobloc housing and a further housing used for locating the additional reduction stage (primary reduction stage), which can be easily installed and connected to the main housing, used even in the two stages versions equipped with PAM (motor pre-arrangement)**
- **Strong and highly resistant structure, suitable to fit even particularly powerful motors and to transmit remarkable torques, both rated and starting ones**
- **Use of standardised motors, directly coupled on to the hollow end of the input shaft**
- **High oil capacity, in view of a highly efficient lubrication**
- **High thermal exchange capacity, with chances to operate even in heavy duty conditions of application.**
- **Considerably low sound levels and minimized vibration risks thank to the modular construction which prevents from the risk of wrong assembling and uncorrect alignments**
- **More reliable and repeatable level of quality of the assembly**
- **Reduced needs of maintenance**

## LUBRICATION

**All PL and PD gearboxes provided with the primary reduction (PL../3, and PD../3) are supplied with the primary reduction already pre-lubricated in-house, and therefore do not require any filling with oil by the customer. It is used mineral oil type ISO VG 220 (see chart 1). On the contrary, PL and PD gearboxes with 2 stages of reduction, as well as the main housing in the versions with primary reduction are supplied without oil, and the relative lubrication is at customer's account.**

## KONSTRUKTIVE EIGENSCHAFTEN

- *Kompakte Einheit und hohe Vielseitigkeit in der Anwendung*
- *Einheitliche Bauform, so daß die Montage in allen Einbaulagen problemlos erfolgen kann*
- *Das Hauptgehäuse (Monoblock) ist gleichzeitig für den Anbau einer Vorstufe für höhere Untersetzungen vorgesehen, die auch in der Version für Motoranbau (PAM) leicht zu montieren ist*
- *Eine robuste Konzeption und Bauweise erlaubt den Anbau größerer Motoren, um höhere Anlauf - bzw. Nennmomente zu übertragen*
- *Verwendung von Normmotoren die direkt mit der Eingangshohlwelle gekoppelt werden*
- *Ausreichender Innenraum im Gehäuse erlaubt den Einsatz der Getriebe auch in extremen Einsatzfällen*
- *Bedingt durch die Modul-Bauweise und Montage werden Geräusche und Vibration sowie Montagefehler vermindert*
- *Gleichbleibend hohe Qualität des fertigen Produkts*
- *Geringer Bedarf an Wartung*

## SCHMIERUNG

*Bei allen Getrieben der Type PL und PD mit Vorstufe (PL../3 und PD../3), wird die Vorstufe bereits vom Hersteller aus mit Schmiermittel geliefert, so daß von Kundenseite her kein zusätzliches Schmiermittel in die Vorstufe einzufüllen ist. Hierbei wird ein Mineralöl von Shell der Type ISO VG 220 verwendet (siehe Tabelle 1). Die zweistufigen PL und PD Getriebe sowie die Hauptgehäuse der Vorstufengetriebe werden alle ohne jegliches Schmiermittel geliefert. Es ist somit Aufgabe des Kunden, diese vor der Inbetriebnahme mit Öl zu füllen.*

Si raccomanda di attenersi scrupolosamente alle tabelle dei lubrificanti qui sotto indicati:

**We recommend to strictly adhere to the table of lubricants mentioned here below:**

*Grundsätzlich empfiehlt es sich die nachfolgenden Schmiermittel zu verwenden:*

TABELLA 1 – LUBRIFICANTI MINERALI

TABLE 1 - MINERAL LUBRICANTS

TABELLE 1 - MINERALSCHMIERMITTEL

MARCA / MAKE / HERSTELLER	TIPO DI OLIO / TYPE OF OIL / ÖLSORTE
<ul style="list-style-type: none"> <li>• SHELL</li> <li>• IP</li> <li>• MOBIL</li> <li>• ESSO</li> </ul>	OMALA OIL 220 MELLANA OIL 220 MOBILGEAR 630 SPARTAN EP220

TEMPERATURA AMBIENTE / AMBIENT TEMPERATURE / UMGEBUNGSTEMPERATUR - 5 °C ÷ + 35 °C

TABELLA 2 – LUBRIFICANTI SINTETICI

TABLE 2 - SYNTHETIC LUBRICANTS

TABELLE 2 - SYNTHETISCHE SCHMIERMITTEL

MARCA / MAKE / HERSTELLER	TIPO DI OLIO / TYPE OF OIL / ÖLSORTE
<ul style="list-style-type: none"> <li>• SHELL</li> <li>• IP</li> <li>• KLÜBER</li> </ul>	TIVELA OIL SC 320 TELIUM OIL 320 SYNTHESO D 320 EP

TEMPERATURA AMBIENTE / AMBIENT TEMPERATURE / UMGEBUNGSTEMPERATUR - 30 °C ÷ + 50 °C

Gli anelli di tenuta, costruiti in mescole nitriliche, non consentono però di operare soddisfacentemente a temperatura superiore a + 85 °C.

Nell'ipotesi che la temperatura all'interno del riduttore possa raggiungere livelli più elevati di + 85 °C per tempi significativi, è necessario richiederci l'esecuzione speciale con anelli di tenuta in mescole fluorurate (Viton).

Al fine di predisporre il corretto orientamento dei tappi e per una adeguata lubrificazione dei cuscinetti, è importante precisare sempre la posizione di montaggio desiderata.

NOTA: è opportuno controllare, attraverso il tappo di livello trasparente, collocato nella giusta posizione, se il livello dell'olio si mantiene corretto e non si verificano anomalie, come potrebbe essere determinato da sia pure molto improbabili perdite di olio attraverso gli anelli di tenuta.

In caso di occasionali necessità di ripristino del giusto livello, utilizzare lo stesso olio già presente nel riduttore.

#### Sostituzione dell'olio

L'intervallo di ricambio del lubrificante dipende dalle condizioni di impiego riassunte brevemente nel prospetto sotto indicato:

Temperatura olio	Servizio	Intervallo di ricambio
< 60 °C	Continuo intermittente	5000 (h) 8000 (h)
> 60 °C	Continuo intermittente	2500 (h) 5000 (h)

I dati indicati nel prospetto si riferiscono a lubrificanti a base minerale e sintetici. Questi ultimi se usati in un campo di temperature normali possono essere utilizzati per una lubrificazione a lunga vita, avendo però l'accuratezza di evitare l'inquinamento dei lubrificanti stessi.

**Seals, being made in nitrile rubber compounds, do not allow to operate satisfactorily at temperatures over + 85 °C. In the assumption temperature inside the gearbox achieves higher values than + 85 °C for a significant period of time, it is necessary to require the special execution provided with special seals in fluorurated compounds (Viton).**

**To enable us to fit plugs in suitable positions and for adequate lubrication of the bearings, customers should always specify the required mounting position.**

**NOTE: it is convenient to check through the proper transparent oil level plug that the oil level keeps at the correct value and no failures have occurred, as it could happen in case of unlikely leaks.**

**In case of occasional needs to restore the correct level, the same type of oil must be used.**

#### Replacement of oil

The intervals at which oil must be replaced depend on the conditions of usage, summarized in the table here below:

Oil temperature	Duty	Time interval
< 60 °C	Continuous intermittent	5000 (h) 8000 (h)
> 60 °C	Continuous intermittent	2500 (h) 5000 (h)

The data on the table apply to both mineral base or synthetic base oils. These last ones (especially the 320 grade), whenever used in a normal range of temperatures, can be used for longtime lubrication, but it must be accurately avoided the oil pollution.

*Die Wellendichtringe aus Nitrilmischungen (Standard) vertragen eine Betriebstemperatur von maximal 85 °C. Bei höheren Betriebstemperaturen ab 85 °C über einen längeren Zeitraum hinweg, sollten spezielle Wellendichtringe aus Fluoridmischungen (Viton) eingesetzt werden.*

*Um die Ölschrauben Korrekt zu positionieren und um die geeignete Schmierung der Lager zu gewährleisten fragen wir, immer die Einbaulage bekannt zu geben.*

*Ist die Einbaulage bei der Bestellung bekannt, so werden die Ölschrauben direkt vom Hersteller positioniert.*

*BEMERKUNG: Es ist ratsam, von Zeit zu Zeit den Ölstand durch das Ölstandsauge zu kontrollieren.*

*So können Anomalien, die z.B. durch Wellendichtringe auftreten können, verhindert werden. Im Falle daß Öl, nachgefüllt werden muß, ist die gleiche Ölart zu verwenden.*

#### Ölwechsel

*Der Ölwechselintervall hängt von der Belastungsart ab und ist in Kurzform im Schaubild unten ersichtlich.*

Öltemperatur	Betriebsart	Ölwechselintervall
< 60 °C	dauernd aussetzend	5000 (h) 8000 (h)
> 60 °C	dauernd aussetzend	2500 (h) 5000 (h)

*Die angegebenen Daten beziehen sich auf Synthetik- und Mineralschmiermittel. Wenn Verunreinigungen vermieden werden, können die synthetischen Schmiermittel bei normaler Betriebstemperatur als dauerndes Schmiermittel angesehen werden.*



Quantità di olio in funzione della posizione di montaggio

Oil quantity according to the mounting position

Ölmenge in Abhängigkeit von der Einbaulage

Olio (litri) Oil (liters) Öl (Liter)	Posiz. di mont. Mounting position Einbaulage	PL..				
		Carcassa principale / Main housing / Hauptgehäuse				
		63	80	100	125	160
	B3 - B8	0.9	1.5	2.8	5.6	10
	B6	1.4	2.1	4.0	7.6	12.5
	B7	1.1	1.8	3.6	7.0	11.7
	V5 - V6	1.2	1.9	3.8	7.2	12.0

PL../3				
63	80	100	125	160
0.2	0.3	0.4	0.6	0.8

Precoppia su PL../3 già lubrificata dalla SITI  
Primary reduction PL../3 prelubricated by SITI  
Vorstufe PL../3 geschmiert bei SITI

Olio (litri) Oil (liters) Öl (Liter)	Posiz. di mont. Mounting position Einbaulage	PD..				
		Carcassa principale / Main housing / Hauptgehäuse				
		63	80	100	125	160
	B3	1.1	1.6	2.8	5.5	10
	B6 - B7	0.8	1.4	2.6	5.3	9.8
	B8	1.0	1.7	3.5	6.6	11.2
	V5 - V6	1.1	1.8	3.6	6.8	11.6

PD../3				
63	80	100	125	160
0.2	0.3	0.4	0.6	0.8

Precoppia su PD../3 già lubrificata dalla SITI  
Primary reduction PD../3 prelubricated by SITI  
Vorstufe PD../3 geschmiert bei SITI

## POSIZIONI DI MONTAGGIO

Si consiglia di prestare la massima attenzione alla posizione di montaggio in cui si troverà a lavorare il riduttore. Per molte posizioni, infatti, è prevista un'apposita lubrificazione del riduttore e dei cuscinetti, senza la quale non è garantita la normale durata del riduttore stesso. In mancanza di indicazioni specifiche il riduttore verrà fornito idoneo per il montaggio standard B3.

## MOUNTING POSITIONS

We recommend paying the utmost attention to the gearbox installation and operating position. For many positions, in fact, a specific lubrication of the gearbox and its bearings is required, without which the normal service life of the gearbox will not be guaranteed. Without any specific indications the gearbox will be supplied for the standard B3 installation.

## EINBAULAGE

Man sollte immer sehr genau auf die Einbaulage achten, wo das Getriebe arbeiten wird. Denn für viele Einbaulagen ist eine Spezialschmierung des Getriebes und seiner Lager vorgesehen, ohne die die normale Lebensdauer des Getriebes nicht garantiert ist. In Ermangelung spezifischer Angaben wird das Getriebe für die Standard-Einbaulage B3 geliefert.

PL  
PL../3

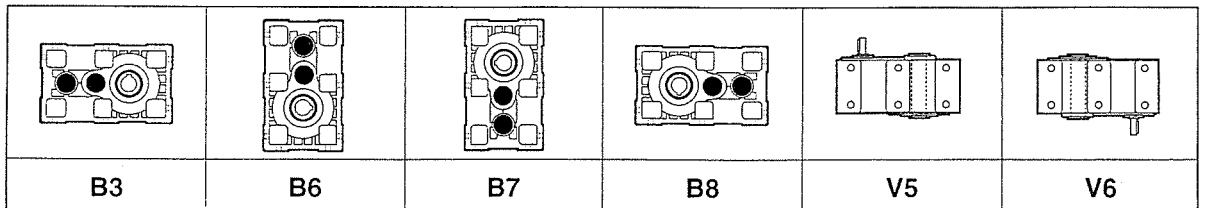

PD  
PD../3

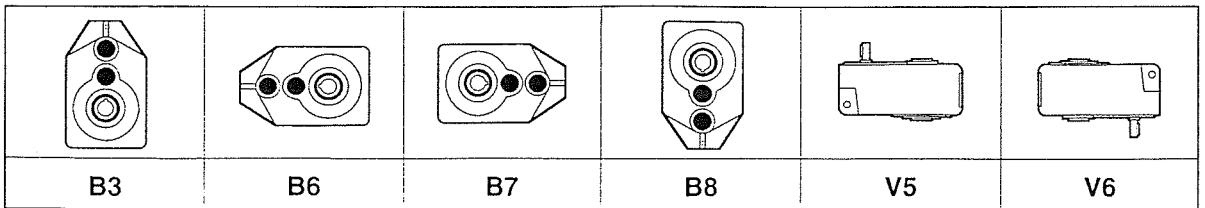

## SENSO DI ROTAZIONE

## SENSE OF ROTATION

## DREHRICHTUNG

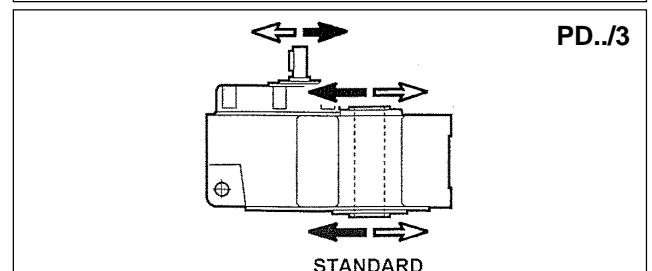
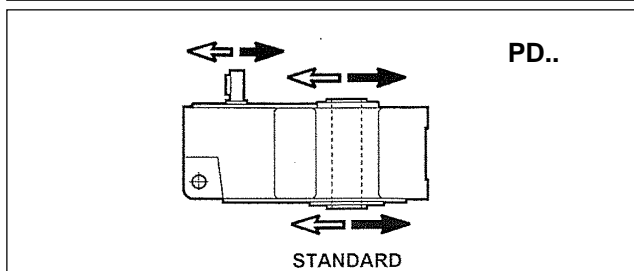
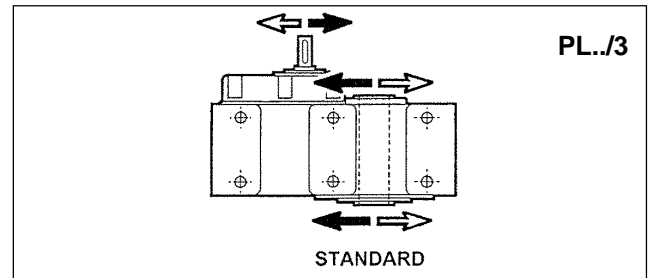
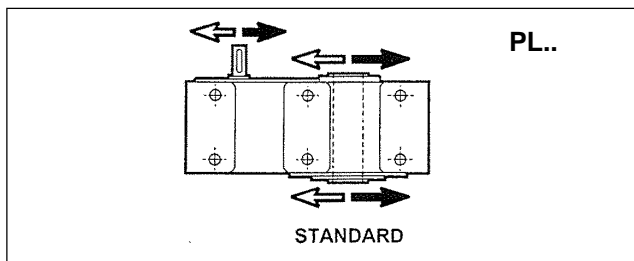

DESIGNAZIONE

CONFIGURATION

TYPENBEZEICHNUNG

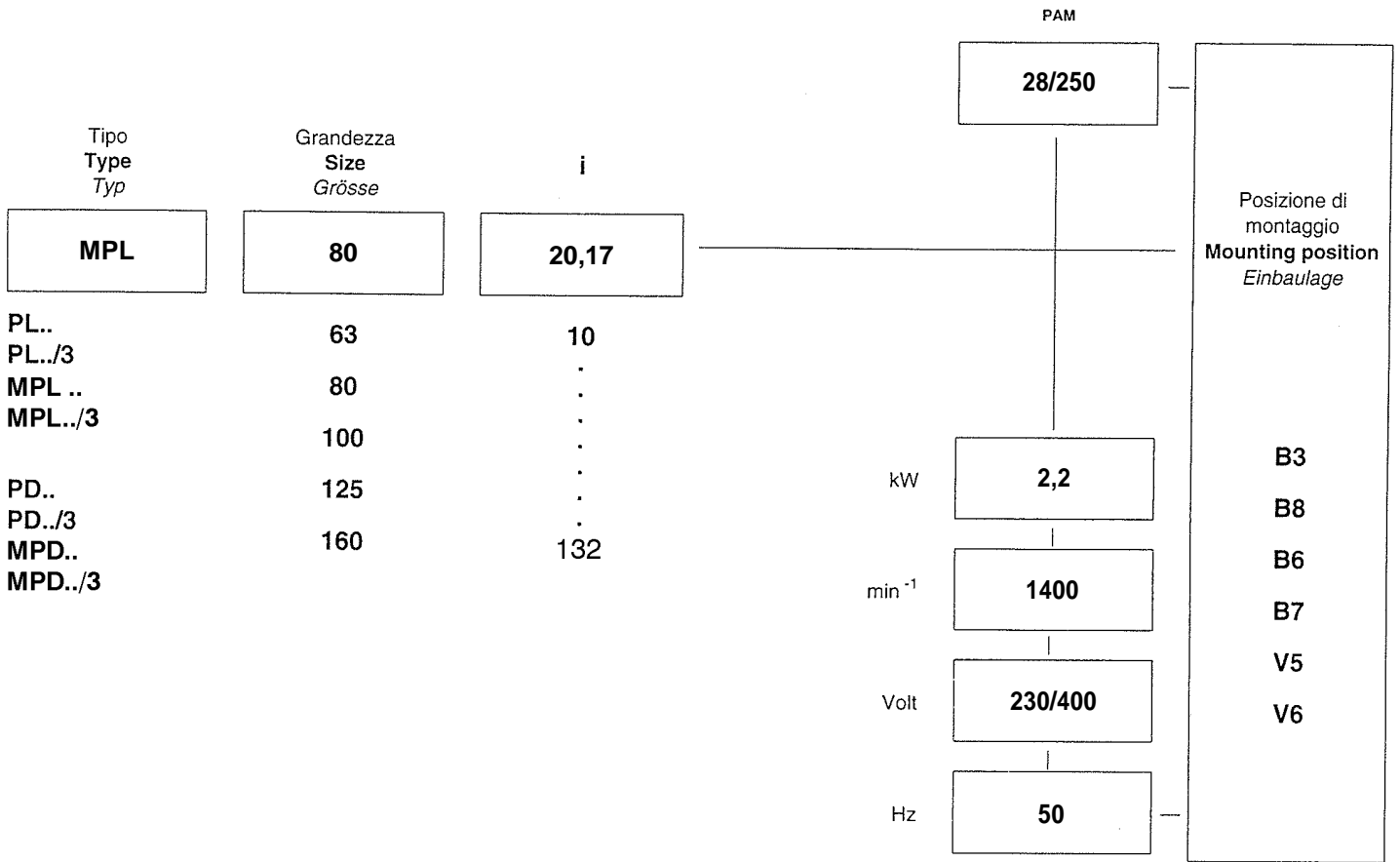

Precisare eventuali particolarità:  
**Clarify possible options:**  
*Eventuelle Sonderausführungen zeigen:*

ALBERO LENTO SEMPLICE  
**SINGLE OUTPUT SHAFT**  
*EINSEITIGE STECKWELLE*

ALBERO LENTO DOPPIO  
**DOUBLE OUTPUT SHAFT**  
*DOPPELSEITIGE STECKWELLE*

FLANGIA USCITA  
**OUTPUT FLANGE**  
*ABTRIEBSFLANSCH*

ETC...

## PL 63

### PRESTAZIONI

### PERFORMANCES

### LEISTUNG

## MPL 63

n <sub>1</sub>	i	n <sub>2</sub>	M <sub>2</sub> (Nm)	kW <sub>1</sub>	HP <sub>1</sub>	RD
2800	10.60	264	180	5.2	7.1	0.96
	13.65	205	180	4.0	5.5	0.96
	15.01	187	180	3.7	5.0	0.96
	17.97	156	216	3.7	5.0	0.96
	18.71	150	153	2.5	3.4	0.96
	23.12	121	207	2.7	3.7	0.96
	25.42	110	207	2.5	3.4	0.96
31.69	88	162	1.6	2.1	0.96	
1400	10.60	132	200	2.9	3.9	0.96
	13.65	103	200	2.2	3.0	0.96
	15.01	93	200	2.0	2.8	0.96
	17.97	78	240	2.0	2.8	0.96
	18.71	75	170	1.4	1.9	0.96
	23.12	61	230	1.5	2.1	0.96
	25.42	55	230	1.4	1.9	0.96
31.69	44	180	0.9	1.2	0.96	
900	10.60	85	220	2.0	2.8	0.96
	13.65	66	220	1.6	2.2	0.96
	15.01	60	220	1.4	2.0	0.96
	17.97	50	264	1.4	2.0	0.96
	18.71	48	187	1.0	1.3	0.96
	23.12	39	253	1.1	1.5	0.96
	25.42	35	253	1.0	1.3	0.96
31.69	28	198	0.6	0.8	0.96	

n <sub>1</sub>	i	n <sub>2</sub>	M <sub>2</sub> (Nm)	kW <sub>1</sub>	HP <sub>1</sub>	RD	fs	P.A.M.
2800	10.60	264	76	2.2	3	0.96	2.36	24/200 - 19/200
	13.65	205	98	2.2	3	0.96	1.83	24/200 - 19/200
	15.01	187	108	2.2	3	0.96	1.66	24/200 - 19/200
	17.97	156	129	2.2	3	0.96	1.67	24/200 - 19/200
	18.71	150	135	2.2	3	0.96	1.14	24/200 - 19/200
	23.12	121	167	2.2	3	0.96	1.24	24/200 - 19/200
	25.42	110	125	1.5	2	0.96	1.66	24/200 - 19/200
31.69	88	156	1.5	2	0.96	1.04	24/200 - 19/200	
1400	10.60	132	125	1.8	2.5	0.96	1.60	24/200 - 19/200
	13.65	103	161	1.8	2.5	0.96	1.24	24/200 - 19/200
	15.01	93	177	1.8	2.5	0.96	1.13	24/200 - 19/200
	17.97	78	212	1.8	2.5	0.96	1.13	24/200 - 19/200
	18.71	75	184	1.5	2	0.96	0.92	24/200 - 19/200
	23.12	61	227	1.5	2	0.96	1.01	24/200 - 19/200
	25.42	55	183	1.1	1.5	0.96	1.26	24/200 - 19/200
31.69	44	156	0.75	1	0.96	1.16	24/200 - 19/200	
900	10.60	85	119	1.1	1.5	0.96	1.85	24/200 - 19/200
	13.65	66	153	1.1	1.5	0.96	1.44	24/200 - 19/200
	15.01	60	168	1.1	1.5	0.96	1.31	24/200 - 19/200
	17.97	50	201	1.1	1.5	0.96	1.31	24/200 - 19/200
	18.71	48	210	1.1	1.5	0.96	0.89	24/200 - 19/200
	23.12	39	259	1.1	1.5	0.96	0.98	24/200 - 19/200
	25.42	35	194	0.75	1	0.96	1.30	24/200 - 19/200
31.69	28	178	0.55	0.75	0.96	1.12	24/200 - 19/200	

### DIMENSIONI D'INGOMBRO

### OVERALL DIMENSIONS

### ALLGEMEINE ABMESSUNGEN

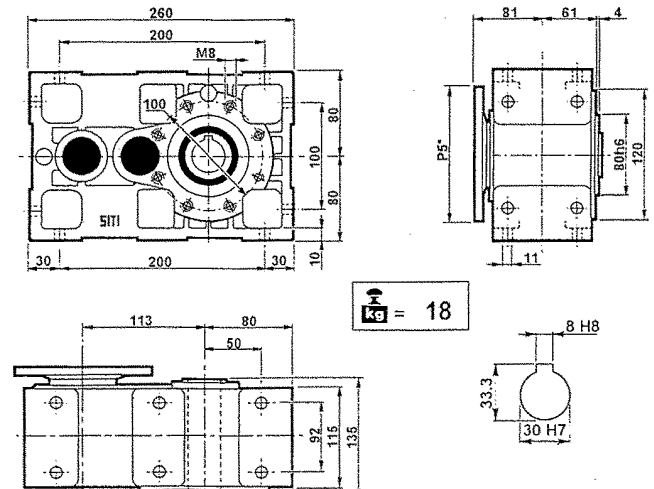
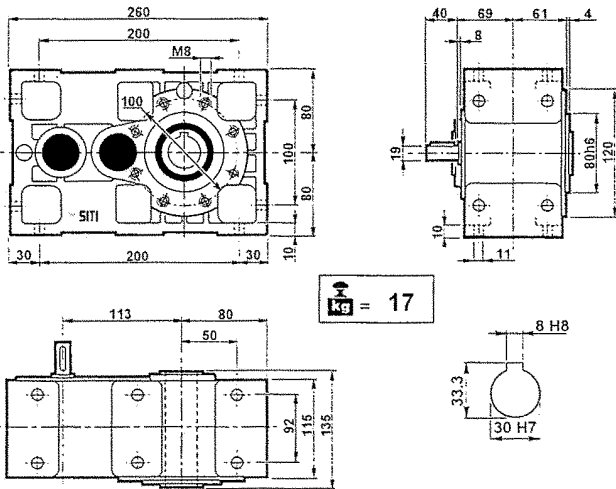

PL 63

MPL 63

P<sub>5</sub>\* : Vedere i PAM per ogni singola versione  
P<sub>5</sub>\* : See PAM size for each single version  
P<sub>5</sub>\* : Siehe PAM Größe für jede Ausführung

### CARICHI RADIALI (N)

### OVERHUNG LOADS (N)

### RADIALE BELASTUNGEN (N)

ALBERO VELOCE / INPUT SHAFT / EINGANGSWELLE		
	PL 63	PL 63/3
1400 min <sup>-1</sup>	650	400

ALBERO LENTO / OUTPUT SHAFT / ABTRIEBSWELLE							
PL 63 - PL 63/3							
min <sup>-1</sup>	0°	30°	60°	90°	120°	150°	180°
20	9205	9517	10327	11572	13002	14121	14562
40	6961	7276	8022	9267	10700	11880	12320
60	5911	6159	6907	8150	9582	10762	11259
80	5164	5413	6159	7404	8836	10079	10514
100	4666	4916	5598	6838	8271	9500	10016
120	4291	4480	5225	6409	7902	9145	9643
140	3982	4156	4848	5946	7332	8486	8948
160	3732	3896	4544	5574	6872	7954	8386

Rotazione oraria  
Clockwise  
rotation  
Uhrzeigersinn

Rotazione antioraria  
Anticlockwise  
rotation  
Gegenuhrzeigersinn

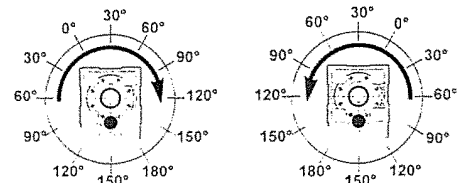

## PL 63/3

## PRESTAZIONI

## PERFORMANCES

## LEISTUNG

## MPL 63/3

$n_1$	$i$	$n_2$	$M_2$ (Nm)	$kW_1$	$HP_1$	RD
2800	29.25	96	252	2.7	3.7	0.92
	37.68	74	270	2.3	3.1	0.92
	41.43	68	252	1.9	2.6	0.92
	47.53	59	180	1.2	1.6	0.92
	51.66	54	198	1.2	1.7	0.92
	58.72	48	270	1.5	2.0	0.92
	64.55	43	252	1.2	1.7	0.92
	67.37	42	198	0.9	1.3	0.92
	80.5	35	198	0.8	1.1	0.92
	83.22	34	270	1.0	1.4	0.92
	91.49	31	252	0.9	1.2	0.92
114.09	25	198	0.6	0.8	0.92	

$n_1$	$i$	$n_2$	$M_2$ (Nm)	$kW_1$	$HP_1$	RD	$f_s$	P.A.M.
2800	29.25	96	138	1.5	2	0.92	1.83	19/200 - 14/160
	37.68	74	177	1.5	2	0.92	1.52	19/200 - 14/160
	41.43	68	195	1.5	2	0.92	1.29	19/200 - 14/160
	47.53	59	112	0.75	1	0.92	1.61	14/160
	51.66	54	178	1.1	1.5	0.92	1.11	19/200 - 14/160
	58.72	48	138	0.75	1	0.92	1.95	14/160
	64.55	43	152	0.75	1	0.92	1.66	14/160
	67.37	42	53	0.25	0.34	0.92	3.75	11/140
	80.5	35	189	0.75	1	0.92	1.05	14/160
	83.22	34	65	0.25	0.34	0.92	4.14	11/140
	91.49	31	72	0.25	0.34	0.92	3.51	11/140
114.09	25	89	0.25	0.34	0.92	2.21	11/140	

1400	29.25	48	280	1.5	2.1	0.92
	37.68	37	300	1.3	1.7	0.92
	41.43	34	280	1.1	1.5	0.92
	47.53	29	200	0.7	0.9	0.92
	51.66	27	220	0.7	0.9	0.92
	58.72	24	300	0.8	1.1	0.92
	64.55	22	280	0.7	0.9	0.92
	67.37	21	220	0.5	0.7	0.92
	80.5	17	220	0.4	0.6	0.92
	83.22	17	300	0.6	0.8	0.92
	91.49	15	280	0.5	0.7	0.92
114.09	12	220	0.3	0.4	0.92	

1400	29.25	48	138	0.75	1	0.92	2.03	19/200 - 14/160
	37.68	37	177	0.75	1	0.92	1.69	19/200 - 14/160
	41.43	34	195	0.75	1	0.92	1.44	19/200 - 14/160
	47.53	29	110	0.37	0.5	0.92	1.81	14/160
	51.66	27	243	0.75	1	0.92	0.90	19/200 - 14/160
	58.72	24	136	0.37	0.5	0.92	2.20	14/160
	64.55	22	150	0.37	0.5	0.92	1.87	14/160
	67.37	21	76	0.18	0.25	0.92	2.89	11/140
	80.5	17	187	0.37	0.50	0.92	1.18	14/160
	83.22	17	94	0.18	0.25	0.92	3.19	11/140
	91.49	15	103	0.18	0.25	0.92	2.71	11/140
114.09	12	129	0.18	0.25	0.92	1.71	11/140	

900	29.25	31	308	1.1	1.5	0.92
	37.68	24	330	0.9	1.2	0.92
	41.43	22	308	0.8	1.0	0.92
	47.53	19	220	0.5	0.6	0.92
	51.66	17	242	0.5	0.7	0.92
	58.72	15	330	0.6	0.8	0.92
	64.55	14	308	0.5	0.7	0.92
	67.37	13	242	0.4	0.5	0.92
	80.5	11	242	0.3	0.4	0.92
	83.22	11	330	0.4	0.6	0.92
	91.49	10	308	0.3	0.5	0.92
114.09	8	242	0.2	0.3	0.92	

900	29.25	31	157	0.55	0.75	0.92	1.96	19/200 - 14/160
	37.68	24	202	0.55	0.75	0.92	1.63	19/200 - 14/160
	41.43	22	222	0.55	0.75	0.92	1.38	19/200 - 14/160
	47.53	19	216	0.25	0.34	0.92	1.90	14/160
	51.66	17	277	0.55	0.75	0.92	0.87	19/200 - 14/160
	58.72	15	143	0.25	0.34	0.92	2.30	14/160
	64.55	14	158	0.25	0.34	0.92	1.96	14/160
	67.37	13	79	0.12	0.16	0.92	3.07	11/140
	80.5	11	196	0.25	0.34	0.92	1.23	14/160
	83.22	11	97	0.12	0.16	0.92	3.8	11/140
	91.49	10	107	0.12	0.16	0.92	2.87	11/140
114.09	8	134	0.12	0.16	0.92	1.81	11/140	

## DIMENSIONI D'INGOMBRO

## OVERALL DIMENSIONS

## ALLGEMEINE ABMESSUNGEN

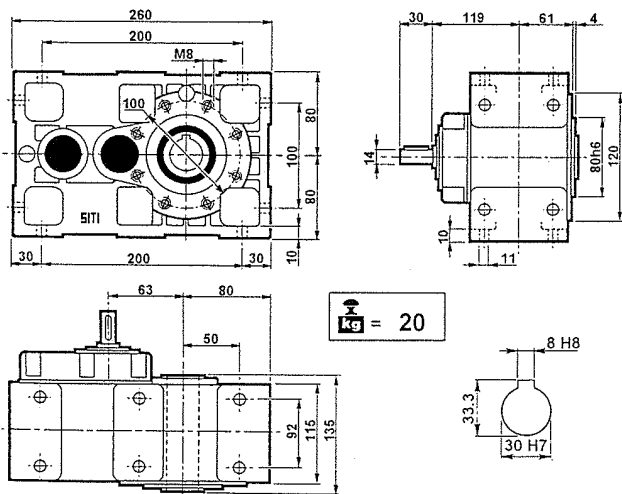

PL 63/3

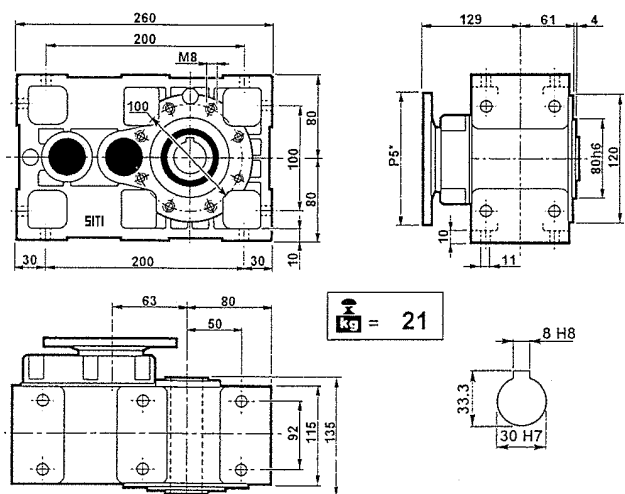

MPL 63/3

$P_5^*$  : Vedere i PAM per ogni singola versione  
 $P_5^*$  : See PAM size for each single version  
 $P_5^*$  : Siehe PAM Grösse für jede Ausführung

## PL 80

### PRESTAZIONI

### PERFORMANCES

### LEISTUNG

## MPL 80

n <sub>1</sub>	i	n <sub>2</sub>	M <sub>2</sub> (Nm)	kW <sub>1</sub>	HP <sub>1</sub>	RD
2800	10.02	279	360	11.0	14.9	0.96
	12.94	216	360	8.5	11.6	0.96
	15.78	177	360	7.0	9.5	0.96
	17.95	156	441	7.5	10.2	0.96
	20.17	139	405	6.1	8.3	0.96
	23.17	121	378	5.0	6.8	0.96
	28.26	99	378	4.1	5.6	0.96
36.13	77	360	3.0	4.1	0.96	
1400	10.02	140	400	6.1	8.3	0.96
	12.94	108	400	4.7	6.4	0.96
	15.78	89	400	3.9	5.3	0.96
	17.95	78	490	4.2	5.7	0.96
	20.17	69	450	3.4	4.6	0.96
	23.17	60	420	2.8	3.8	0.96
	28.26	50	420	2.3	3.1	0.96
36.13	39	400	1.7	2.3	0.96	
900	10.02	90	440	4.3	5.9	0.96
	12.94	70	440	3.3	4.5	0.96
	15.78	57	440	2.7	3.7	0.96
	17.95	50	539	2.9	4.0	0.96
	20.17	45	495	2.4	3.3	0.96
	23.17	39	462	2.0	2.7	0.96
	28.26	32	462	1.6	2.2	0.96
36.13	25	440	1.2	1.6	0.96	

n <sub>1</sub>	i	n <sub>2</sub>	M <sub>2</sub> (Nm)	kW <sub>1</sub>	HP <sub>1</sub>	RD	fs	P.A.M.
2800	10.02	279	180	5.5	7.5	0.96	2.00	28/250 - 24/200
	12.94	216	233	5.5	7.5	0.96	1.54	28/250 - 24/200
	15.78	177	284	5.5	7.5	0.96	1.27	28/250 - 24/200
	17.95	156	323	5.5	7.5	0.96	1.36	28/250 - 24/200
	20.17	139	363	5.5	7.5	0.96	1.11	28/250 - 24/200
	23.17	121	303	4	5.5	0.96	1.25	28/250 - 24/200
	28.26	99	370	4	5.5	0.96	1.02	28/250 - 24/200
36.13	77	260	2.2	3	0.96	1.38	28/250 - 24/200	
1400	10.02	140	262	4	5.5	0.96	1.52	28/250 - 24/200
	12.94	108	339	4	5.5	0.96	1.18	28/250 - 24/200
	15.78	89	310	3	4	0.96	1.29	28/250 - 24/200
	17.95	78	470	4	5.5	0.96	1.04	28/250 - 24/200
	20.17	69	396	3	4	0.96	1.14	28/250 - 24/200
	23.17	60	334	2.2	3	0.96	1.26	28/250 - 24/200
	28.26	50	407	2.2	3	0.96	1.03	28/250 - 24/200
36.13	39	365	1.5	2	0.96	1.13	28/250 - 24/200	
900	10.02	90	225	2.2	3	0.96	1.96	28/250 - 24/200
	12.94	70	290	2.2	3	0.96	1.52	28/250 - 24/200
	15.78	57	354	2.2	3	0.96	1.24	28/250 - 24/200
	17.95	50	402	2.2	3	0.96	1.34	28/250 - 24/200
	20.17	45	452	2.2	3	0.96	1.10	28/250 - 24/200
	23.17	39	354	1.5	2	0.96	1.30	28/250 - 24/200
	28.26	32	432	1.5	2	0.96	1.07	28/250 - 24/200
36.13	25	405	1.1	1.5	0.96	1.09	28/250 - 24/200	

### DIMENSIONI D'INGOMBRO

### OVERALL DIMENSIONS

### ALLGEMEINE ABMESSUNGEN

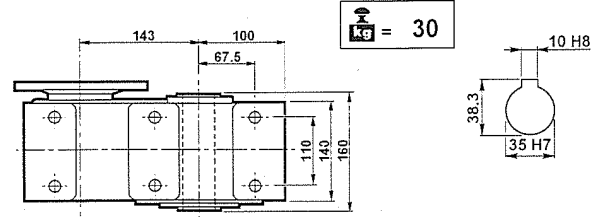
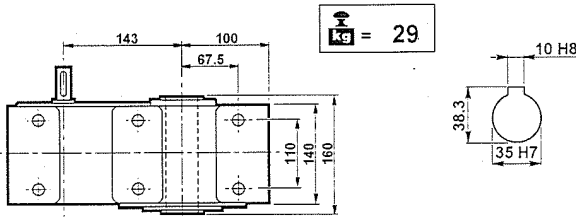
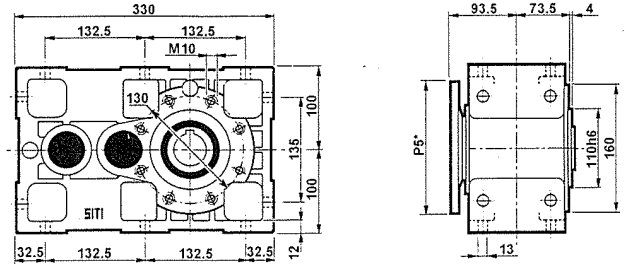
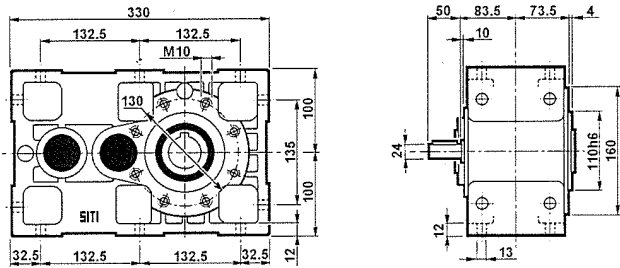

PL 80

MPL 80

P<sub>5</sub>\* : Vedere i PAM per ogni singola versione  
P<sub>5</sub>\* : See PAM size for each single version  
P<sub>5</sub>\* : Siehe PAM Grösse für jede Ausführung

### CARICHI RADIALI (N)

### OVERHUNG LOADS (N)

### RADIALE BELASTUNGEN (N)

ALBERO VELOCE / INPUT SHAFT / EINGANGSWELLE		
	PL 80	PL 80/3
1400 min <sup>-1</sup>	900	650

ALBERO LENTO / OUTPUT SHAFT / ABTRIEBSWELLE							
PL 80 - PL 80/3							
min <sup>-1</sup>	0°	30°	60°	90°	120°	150°	180°
20	9995	10333	11213	12565	14118	15332	15811
40	7558	7900	8710	10062	11618	12899	13377
60	6418	6687	7499	8849	10403	11685	12225
80	5607	5878	6687	8039	9594	10944	11416
100	5066	5337	6078	7425	8981	10314	10375
120	4659	4864	5673	6959	8580	9930	10470
140	4323	4513	5264	6457	7961	9214	9715
160	4052	4230	4934	6052	7462	8636	9106

Rotazione oraria  
Clockwise  
rotation  
Uhrzeigersinn

Rotazione antioraria  
Anticlockwise  
rotation  
Gegenurzeigersinn

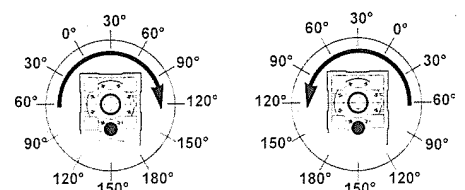

## PL 80/3

### PRESTAZIONI

### PERFORMANCES

### LEISTUNG

## MPL 80/3

n <sub>1</sub>	i	n <sub>2</sub>	M <sub>2</sub> (Nm)	kW <sub>1</sub>	HP <sub>1</sub>	RD
2800	24.45	115	459	6.0	8.1	0.92
	31.57	89	459	4.6	6.3	0.92
	38.47	73	450	3.7	5.1	0.92
	46.91	60	432	2.9	4.0	0.92
	49.22	57	360	2.3	3.2	0.92
	56.54	50	459	2.6	3.5	0.92
	59.97	47	360	1.9	2.6	0.92
	68.95	41	441	2.0	2.8	0.92
	84.58	33	468	1.8	2.4	0.92
	88.15	32	378	1.4	1.9	0.92
	103.15	27	450	1.4	1.9	0.92
	131.86	21	378	0.9	1.2	0.92

n <sub>1</sub>	i	n <sub>2</sub>	M <sub>2</sub> (Nm)	kW <sub>1</sub>	HP <sub>1</sub>	RD	P.A.M.	
2800	24.45	115	169	2.2	3	0.92	2.72	24/200 - 19/200
	31.57	89	218	2.2	3	0.92	2.11	24/200 - 19/200
	38.47	73	362	3	4	0.92	1.24	28/250 - 24/200
	46.91	60	442	3	4	0.92	0.98	28/250 - 24/200
	49.22	57	340	2.2	3	0.92	1.06	24/200 - 19/200
	56.54	50	390	2.2	3	0.92	1.18	24/200 - 19/200
	59.97	47	282	1.5	2	0.92	1.28	28/250 - 24/200
	68.95	41	325	1.5	2	0.92	1.36	24/200 - 19/200
	84.58	33	199	0.75	1	0.92	2.35	14/160
	88.15	32	304	1.10	1.5	0.92	1.24	24/200 - 19/200
	103.15	27	243	0.75	1	0.92	1.85	14/160
	131.86	21	310	0.75	1	0.92	1.22	14/160

1400	24.45	57	510	3.3	4.5	0.92
	31.57	44	510	2.6	3.5	0.92
	38.47	36	500	2.1	2.8	0.92
	46.91	30	480	1.6	2.2	0.92
	49.22	28	400	1.3	1.8	0.92
	56.54	25	510	1.4	2.0	0.92
	59.97	23	400	1.1	1.4	0.92
	68.95	20	490	1.1	1.5	0.92
	84.58	17	520	1.0	1.3	0.92
	88.15	16	420	0.8	1.0	0.92
	103.15	14	500	0.8	1.1	0.92
	131.86	11	420	0.5	0.7	0.92

1400	24.45	57	276	1.8	2.5	0.92	1.85	24/200 - 19/200
	31.57	44	357	1.8	2.5	0.92	1.43	24/200 - 19/200
	38.47	36	531	2.2	3	0.92	0.94	28/250 - 24/200
	46.91	30	442	1.5	2	0.92	1.09	28/250 - 24/200
	49.22	28	340	1.1	1.5	0.92	1.18	24/200 - 19/200
	56.54	25	390	1.1	1.5	0.92	1.31	24/200 - 19/200
	59.97	23	414	1.1	1.5	0.92	0.97	28/250 - 24/200
	68.95	20	476	1.1	1.5	0.92	1.03	24/200 - 19/200
	84.58	17	196	0.37	0.5	0.92	2.65	14/160
	88.15	16	415	0.75	1	0.92	1.01	24/200 - 19/200
	103.15	14	240	0.37	0.5	0.92	2.09	14/160
	131.86	11	306	0.37	0.5	0.92	1.37	14/160

900	24.45	37	561	2.4	3.2	0.92
	31.57	29	561	1.8	2.5	0.92
	38.47	23	550	1.5	2.0	0.92
	46.91	19	528	1.2	1.6	0.92
	49.22	18	440	0.9	1.2	0.92
	56.54	16	561	1.0	1.4	0.92
	59.97	15	440	0.8	1.0	0.92
	68.95	13	539	0.8	1.1	0.92
	84.58	11	572	0.7	0.9	0.92
	88.15	10	462	0.5	0.7	0.92
	103.15	9	550	0.5	0.7	0.92
	131.86	7	462	0.4	0.5	0.92

900	24.45	37	263	1.1	1.5	0.92	2.14	24/200 - 19/200
	31.57	29	339	1.1	1.5	0.92	1.65	24/200 - 19/200
	38.47	23	563	1.5	2	0.92	0.98	28/250 - 24/200
	46.91	19	504	1.1	1.5	0.92	1.05	28/250 - 24/200
	49.22	18	360	0.75	1	0.92	1.22	24/200 - 19/200
	56.54	16	414	0.75	1	0.92	1.36	24/200 - 19/200
	59.97	15	439	0.75	1	0.92	1.00	28/250 - 24/200
	68.95	13	505	0.75	1	0.92	1.07	24/200 - 19/200
	84.58	11	206	0.25	0.34	0.92	2.77	14/160
	88.15	10	473	0.55	0.75	0.92	0.89	24/200 - 19/200
	103.15	9	252	0.25	0.34	0.92	2.18	14/160
	131.86	7	322	0.25	0.34	0.92	1.44	14/160

### DIMENSIONI D'INGOMBRO

### OVERALL DIMENSIONS

### ALLGEMEINE ABMESSUNGEN

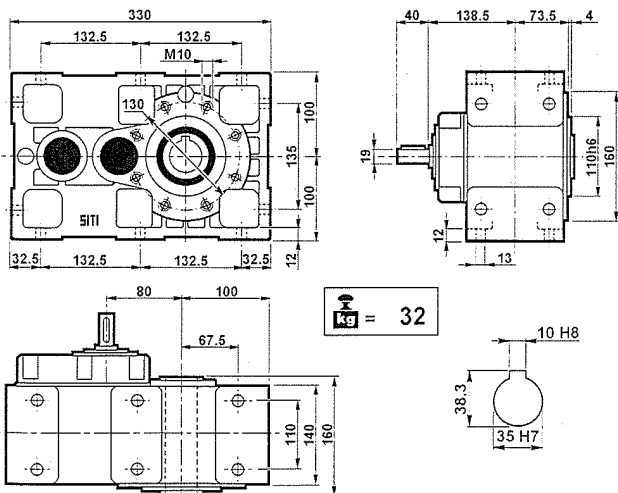

PL 80/3

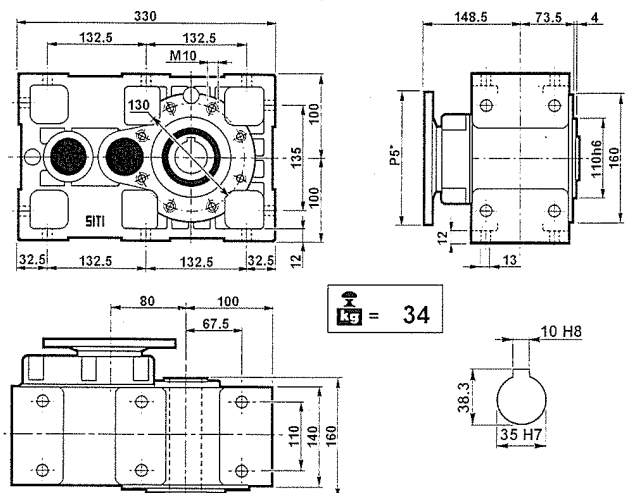

MPL 80/3

P<sub>5</sub>\*: Vedere i PAM per ogni singola versione  
P<sub>5</sub>\*: See PAM size for each single version  
P<sub>5</sub>\*: Siehe PAM Grösse für jede Ausführung



## PL 100

### PRESTAZIONI

### PERFORMANCES

### LEISTUNG

## MPL 100

n <sub>1</sub>	i	n <sub>2</sub>	M <sub>2</sub> (Nm)	kW <sub>1</sub>	HP <sub>1</sub>	RD
----------------	---	----------------	------------------------	-----------------	-----------------	----

2800	9.98	281	720	22.0	30.0	0.96
	12.89	217	720	17.1	23.2	0.96
	15.47	181	855	16.9	23.0	0.96
	15.72	178	720	14.0	19.0	0.96
	19.98	140	810	12.4	16.8	0.96
	20.49	137	675	10.1	13.7	0.96
	24.36	115	810	10.2	13.8	0.96
	31.75	88	675	6.5	8.8	0.96

1400	9.98	140	800	12.2	16.6	0.96
	12.89	109	800	9.5	12.9	0.96
	15.47	90	950	9.4	12.8	0.96
	15.72	89	800	7.8	10.6	0.96
	19.98	70	900	6.9	9.4	0.96
	20.49	68	750	5.6	7.6	0.96
	24.36	57	900	5.6	7.7	0.96
	31.75	44	750	3.6	4.9	0.96

900	9.98	90	880	8.7	11.8	0.96
	12.89	70	880	6.7	9.1	0.96
	15.47	58	1045	6.6	9.0	0.96
	15.72	57	880	5.5	7.5	0.96
	19.98	45	990	4.9	6.6	0.96
	20.49	44	825	4.0	5.4	0.96
	24.36	37	990	4.0	5.4	0.96
	31.75	28	825	2.6	3.5	0.96

n <sub>1</sub>	i	n <sub>2</sub>	M <sub>2</sub> (Nm)	kW <sub>1</sub>	HP <sub>1</sub>	RD	fs	P.A.M.
----------------	---	----------------	------------------------	-----------------	-----------------	----	----	--------

2800	9.98	281	359	11	15	0.96	2.01	38/300 - 28/250
	12.89	217	464	11	15	0.96	1.55	38/300 - 28/250
	15.47	178	557	11	15	0.96	1.54	38/300 - 28/250
	15.72	137	566	11	15	0.96	1.27	38/300 - 28/250
	19.98	181	720	11	15	0.96	1.13	38/300 - 28/250
	20.49	140	604	9	12.5	0.96	1.12	38/300 - 28/250
	24.36	115	718	9	12.5	0.96	1.13	38/300 - 28/250
	31.75	88	672	5.5	7.5	0.96	1.18	38/300 - 28/250

1400	9.98	140	719	11	15	0.96	1.11	38/300 - 28/250
	12.89	109	777	9.2	12.5	0.96	1.03	38/300 - 28/250
	15.47	90	932	9.2	12.5	0.96	1.02	38/300 - 28/250
	15.72	89	772	7.5	10	0.96	1.04	38/300 - 28/250
	19.98	70	720	5.5	7.5	0.96	1.25	38/300 - 28/250
	20.49	68	738	5.5	7.5	0.96	1.02	38/300 - 28/250
	24.36	57	877	5.5	7.5	0.96	1.03	38/300 - 28/250
	31.75	44	624	3	4	0.96	1.20	38/300 - 28/250

900	9.98	90	559	5.5	7.5	0.96	1.57	38/300 - 28/250
	12.89	70	722	5.5	7.5	0.96	1.22	38/300 - 28/250
	15.47	58	867	5.5	7.5	0.96	1.21	38/300 - 28/250
	15.72	57	881	5.5	7.5	0.96	1.00	38/300 - 28/250
	19.98	45	814	4	5.5	0.96	1.22	38/300 - 28/250
	20.49	44	835	4	5.5	0.96	0.99	38/300 - 28/250
	24.36	37	993	4	5.5	0.96	1.00	38/300 - 28/250
	31.75	28	712	2.2	3	0.96	1.16	38/300 - 28/250

### DIMENSIONI D'INGOMBRO

### OVERALL DIMENSIONS

### ALLGEMEINE ABMESSUNGEN

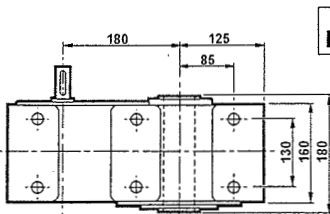
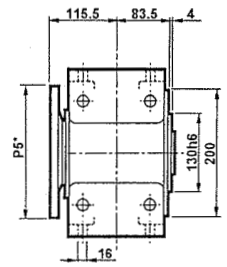
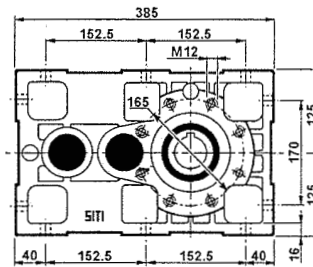
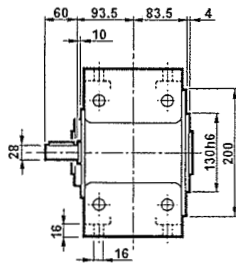
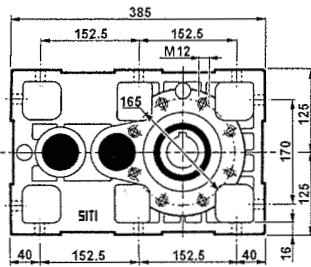

$\frac{L}{W} = 47$

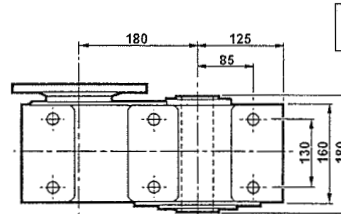
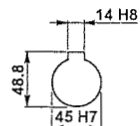

$\frac{L}{W} = 49$

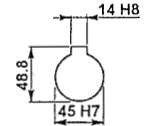

PL 100

MPL 100

P<sub>5</sub>\* : Vedere i PAM per ogni singola versione

P<sub>5</sub>\* : See PAM size for each single version

P<sub>5</sub>\* : Siehe PAM Größe für jede Ausführung

### CARICHI RADIALI (N)

### OVERHUNG LOADS (N)

### RADIALE BELASTUNGEN (N)

ALBERO VELOCE / INPUT SHAFT / EINGANGSWELLE		
	PL 100	PL 100/3
1400 min <sup>-1</sup>	1400	1000

ALBERO LENTO / OUTPUT SHAFT / ABTRIEBSWELLE							
PL 100 - PL 100/3							
min <sup>-1</sup>	0°	30°	60°	90°	120°	150°	180°
20	13186	13632	14793	16577	18625	20227	20859
40	9972	10422	11491	13274	15327	17017	17646
60	8467	8822	9893	11674	13725	15415	16128
80	7397	7754	8822	10606	12657	14438	15060
100	6684	7041	8019	9795	11848	13607	14347
120	6147	6417	7485	9180	11319	13100	13813
140	5704	5954	6945	8518	10502	12155	12817
160	5346	5580	6509	7984	9844	11393	12013

Rotazione oraria  
Clockwise  
rotation  
Uhrzeigersinn

Rotazione antioraria  
Anticlockwise  
rotation  
Gegenuhrzeigersinn

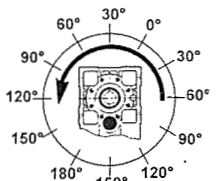
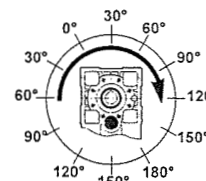

## PL 100/3

### PRESTAZIONI

### PERFORMANCES

### LEISTUNG

## MPL 100/3

n <sub>1</sub>	i	n <sub>2</sub>	M <sub>2</sub> (Nm)	kW <sub>1</sub>	HP <sub>1</sub>	RD
2800	21.40	131	810	12.1	16.4	0.92
	25.68	109	900	11.2	15.2	0.92
	33.16	84	882	8.5	11.5	0.92
	37.74	74	918	7.8	10.5	0.92
	40.44	69	882	7.0	9.5	0.92
	48.74	57	900	5.9	8.0	0.92
	52.70	53	720	4.4	5.9	0.92
	59.44	47	900	4.8	6.6	0.92
	72.91	38	918	4.0	5.5	0.92
	77.47	36	720	3.0	4.0	0.92
	88.91	31	918	3.3	4.5	0.92
	115.88	24	720	2.0	2.7	0.92

n <sub>1</sub>	i	n <sub>2</sub>	M <sub>2</sub> (Nm)	kW <sub>1</sub>	HP <sub>1</sub>	RD	fs	P.A.M.
2800	21.40	131	369	5.5	7.5	0.92	2.19	28/250 - 24/200
	25.68	109	443	5.5	7.5	0.92	2.03	28/250 - 24/200
	33.16	84	572	5.5	7.5	0.92	1.54	28/250 - 24/200
	37.74	74	261	2.2	3	0.92	3.52	24/200 - 19/200
	40.44	69	698	5.5	7.5	0.92	1.26	28/250 - 24/200
	48.74	57	336	2.2	3	0.92	2.67	24/200 - 19/200
	52.70	53	661	4	5.5	0.92	1.09	28/250 - 24/200
	59.44	47	410	2.2	3	0.92	2.19	24/200 - 19/200
	72.91	38	343	1.5	2	0.92	2.68	14/160
	77.47	36	535	2.2	3	0.92	1.35	24/200 - 19/200
	88.91	31	418	1.5	2	0.92	2.19	14/160
	115.88	24	545	1.5	2	0.92	1.32	14/160

n <sub>1</sub>	i	n <sub>2</sub>	M <sub>2</sub> (Nm)	kW <sub>1</sub>	HP <sub>1</sub>	RD
1400	21.40	65	900	6.7	9.1	0.92
	25.68	55	1000	6.2	8.4	0.92
	33.16	42	980	4.7	6.4	0.92
	37.74	37	1020	4.3	5.9	0.92
	40.44	35	980	3.9	5.3	0.92
	48.74	29	1000	3.3	4.4	0.92
	52.70	27	800	2.4	3.3	0.92
	59.44	24	1000	2.7	3.6	0.92
	72.91	19	1020	2.2	3.0	0.92
	77.47	18	800	1.6	2.2	0.92
	88.91	16	1020	1.8	2.5	0.92
	115.88	12	800	1.1	1.5	0.92

n <sub>1</sub>	i	n <sub>2</sub>	M <sub>2</sub> (Nm)	kW <sub>1</sub>	HP <sub>1</sub>	RD	fs	P.A.M.
1400	21.40	65	537	4	5.5	0.92	1.68	28/250 - 24/200
	25.68	55	645	4	5.5	0.92	1.55	28/250 - 24/200
	33.16	42	832	4	5.5	0.92	1.18	28/250 - 24/200
	37.74	37	426	1.8	2.5	0.92	2.39	24/200 - 19/200
	40.44	35	1015	4	5.5	0.92	0.97	28/250 - 24/200
	48.74	29	551	1.8	2.5	0.92	1.82	24/200 - 19/200
	52.70	27	728	2.2	3	0.92	1.10	28/250 - 24/200
	59.44	24	671	1.8	2.5	0.92	1.49	24/200 - 19/200
	72.91	19	343	0.75	1	0.92	2.97	14/160
	77.47	18	729	1.5	2	0.92	1.10	24/200 - 19/200
	88.91	16	418	0.75	1	0.92	2.44	14/160
	115.88	12	545	0.75	1	0.92	1.47	14/160

n <sub>1</sub>	i	n <sub>2</sub>	M <sub>2</sub> (Nm)	kW <sub>1</sub>	HP <sub>1</sub>	RD
900	21.40	42	990	4.7	6.4	0.92
	25.68	35	1100	4.4	6.0	0.92
	33.16	27	1078	3.3	4.5	0.92
	37.74	24	1122	3.0	4.1	0.92
	40.44	22	1078	2.7	3.7	0.92
	48.74	18	1100	2.3	3.1	0.92
	52.70	17	880	1.7	2.3	0.92
	59.44	15	1100	1.9	2.6	0.92
	72.91	12	1122	1.6	2.1	0.92
	77.47	12	880	1.2	1.6	0.92
	88.91	10	1122	1.3	1.8	0.92
	115.88	8	880	0.8	1.1	0.92

n <sub>1</sub>	i	n <sub>2</sub>	M <sub>2</sub> (Nm)	kW <sub>1</sub>	HP <sub>1</sub>	RD	fs	P.A.M.
900	21.40	42	460	2.2	3	0.92	2.15	28/250 - 24/200
	25.68	35	552	2.2	3	0.92	1.99	28/250 - 24/200
	33.16	27	712	2.2	3	0.92	1.51	28/250 - 24/200
	37.74	24	405	1.1	1.5	0.92	2.77	24/200 - 19/200
	40.44	22	869	2.2	3	0.92	1.24	28/250 - 24/200
	48.74	18	523	1.1	1.5	0.92	2.10	24/200 - 19/200
	52.70	17	926	1.8	2.5	0.92	0.95	28/250 - 24/200
	59.44	15	638	1.1	1.5	0.92	1.72	24/200 - 19/200
	72.91	12	391	0.55	0.75	0.92	2.87	14/160
	77.47	12	832	1.1	1.5	0.92	1.06	24/200 - 19/200
	88.91	10	477	0.55	0.75	0.92	2.35	14/160
	115.88	8	622	0.55	0.75	0.92	1.41	14/160

### DIMENSIONI D'INGOMBRO

### OVERALL DIMENSIONS

### ALLGEMEINE ABMESSUNGEN

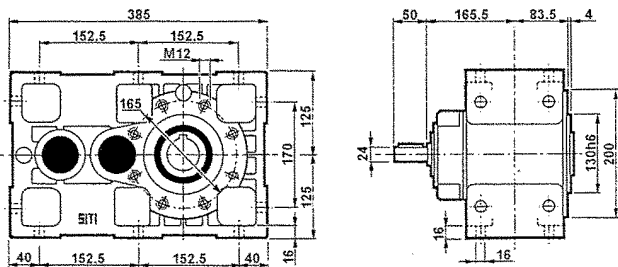

PL 100/3

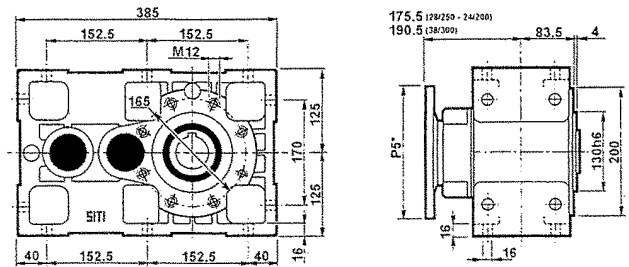

MPL 100/3

P<sub>5</sub>\* : Vedere i PAM per ogni singola versione

P<sub>5</sub>\* : See PAM size for each single version

P<sub>5</sub>\* : Siehe PAM Grösse für jede Ausführung

## PL 125

### PRESTAZIONI

### PERFORMANCES

### LEISTUNG

## MPL 125

n <sub>1</sub>	i	n <sub>2</sub>	M <sub>2</sub> (Nm)	kW <sub>1</sub>	HP <sub>1</sub>	RD
----------------	---	----------------	------------------------	-----------------	-----------------	----

2800	10.48	267	1440	42.0	57.1	0.96
	13.49	208	1440	32.6	44.3	0.96
	16.28	172	1440	27.0	36.7	0.96
	16.43	170	1305	24.3	33.0	0.96
	18.60	151	1620	26.6	36.2	0.96
	20.96	134	1530	22.3	30.3	0.96
	25.52	110	1485	17.8	24.2	0.96
28.90	97	1305	13.8	18.8	0.96	

1400	10.48	134	1600	23.3	31.7	0.96
	13.49	104	1600	18.1	24.6	0.96
	16.28	86	1600	15.0	20.4	0.96
	16.43	85	1450	13.5	18.3	0.96
	18.60	75	1800	14.8	20.1	0.96
	20.96	67	1700	12.4	16.8	0.96
	25.52	55	1650	9.9	13.4	0.96
28.90	48	1450	7.7	10.4	0.96	

900	10.48	86	1760	16.5	22.4	0.96
	13.49	67	1760	12.8	17.4	0.96
	16.28	55	1760	10.6	14.4	0.96
	16.43	55	1595	9.5	13.0	0.96
	18.60	48	1980	10.5	14.2	0.96
	20.96	43	1870	8.8	11.9	0.96
	25.52	35	1815	7.0	9.5	0.96
28.90	31	1595	5.4	7.4	0.96	

n <sub>1</sub>	i	n <sub>2</sub>	M <sub>2</sub> (Nm)	kW <sub>1</sub>	HP <sub>1</sub>	RD	fs	P.A.M.
----------------	---	----------------	------------------------	-----------------	-----------------	----	----	--------

2800	10.48	267	635	18.5	25	0.96	2.27	42/350 - 38/300
	13.49	208	817	18.5	25	0.96	1.76	42/350 - 38/300
	16.28	172	986	18.5	25	0.96	1.46	42/350 - 38/300
	16.43	170	995	18.5	25	0.96	1.31	42/350 - 38/300
	18.60	151	1127	18.5	25	0.96	1.44	42/350 - 38/300
	20.96	134	1270	18.5	25	0.96	1.21	42/350 - 38/300
	25.52	110	1253	15	20	0.96	1.18	42/350 - 38/300
28.90	97	1041	11	15	0.96	1.25	42/350 - 38/300	

1400	10.48	134	1029	15	20	0.96	1.55	42/350 - 38/300
	13.49	104	1325	15	20	0.96	1.21	42/350 - 38/300
	16.28	86	1599	15	20	0.96	1.00	42/350 - 38/300
	16.43	85	1184	11	15	0.96	1.23	42/350 - 38/300
	18.60	75	1827	15	20	0.96	0.99	42/350 - 38/300
	20.96	67	1510	11	15	0.96	1.13	42/350 - 38/300
	25.52	55	1537	9.2	12.5	0.96	1.07	42/350 - 38/300
28.90	48	1419	7.5	10	0.96	1.02	42/350 - 38/300	

900	10.48	86	1174	11	15	0.96	1.50	42/350 - 38/300
	13.49	67	1512	11	15	0.96	1.16	42/350 - 38/300
	16.28	55	1824	11	15	0.96	0.96	42/350 - 38/300
	16.43	55	1255	7.5	10	0.96	1.27	42/350 - 38/300
	18.60	48	2084	11	15	0.96	0.95	42/350 - 38/300
	20.96	43	1601	7.5	10	0.96	1.17	42/350 - 38/300
	25.52	35	1430	5.5	7.5	0.96	1.27	42/350 - 38/300
28.90	31	1619	5.5	7.5	0.96	0.99	42/350 - 38/300	

### DIMENSIONI D'INGOMBRO

### OVERALL DIMENSIONS

### ALLGEMEINE ABMESSUNGEN

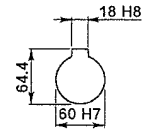
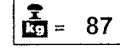
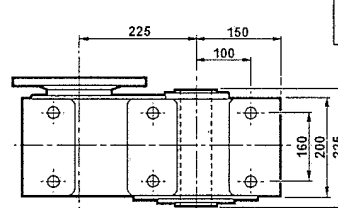
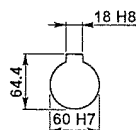
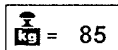
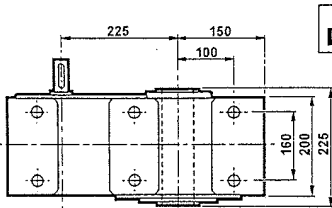
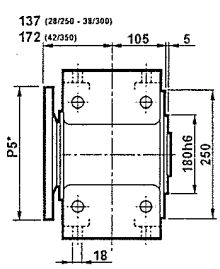
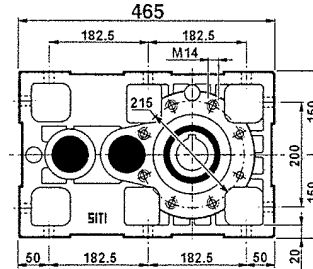
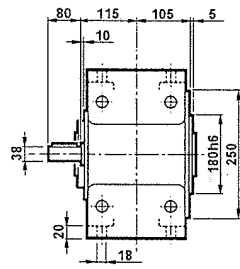
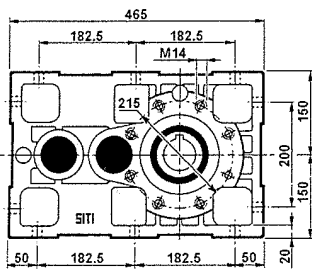

PL 125

MPL 125

P<sub>5</sub>\* : Vedere i PAM per ogni singola versione

P<sub>5</sub>\* : See PAM size for each single version

P<sub>5</sub>\* : Siehe PAM Größe für jede Ausführung

### CARICHI RADIALI (N)

### OVERHUNG LOADS (N)

### RADIALE BELASTUNGEN (N)

ALBERO VELOCE / INPUT SHAFT / EINGANGSWELLE		
	PL 125	PL 125/3
1400 min <sup>-1</sup>	2100	1600

ALBERO LENTO / OUTPUT SHAFT / ABTRIEBSWELLE							
PL 125 - PL 125/3							
min <sup>-1</sup>	0°	30°	60°	90°	120°	150°	180°
20	18837	19474	21133	23681	26607	28896	29799
40	14245	14889	16415	18963	21896	24310	25211
60	12096	12604	14133	16678	19607	22022	23041
80	10567	11078	12604	15152	18081	20626	21515
100	9548	10059	11456	13993	16926	19439	20496
120	8782	9167	10693	13115	16170	18715	19733
140	8148	8505	9921	12168	15003	17364	18309
160	7637	7972	9299	11405	14063	16275	17161

Rotazione oraria  
Clockwise  
rotation  
Uhrzeigersinn

Rotazione antioraria  
Anticlockwise  
rotation  
Gegenuhrzeigersinn

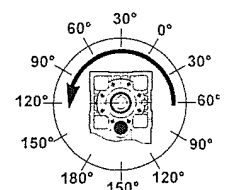
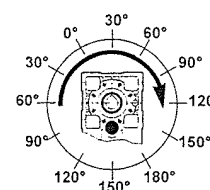

## PL 125/3

### PRESTAZIONI

### PERFORMANCES

### LEISTUNG

## MPL 125/3

n <sub>1</sub>	i	n <sub>2</sub>	M <sub>2</sub> (Nm)	kW <sub>1</sub>	HP <sub>1</sub>	RD
2800	26.47	106	1890	22.8	30.9	0.92
	30.32	92	1395	14.7	19.9	0.92
	34.08	82	1800	16.8	22.9	0.92
	38.46	73	1656	13.7	18.7	0.92
	41.49	67	1620	12.4	16.9	0.92
	47.25	59	1395	9.4	12.8	0.92
	53.11	53	1818	10.9	14.8	0.92
	59.60	47	1890	10.1	13.7	0.92
	64.66	43	1638	8.1	11.0	0.92
	73.22	38	1395	6.1	8.3	0.92
	93.42	30	1665	5.7	7.7	0.92
	105.79	26	1395	4.2	5.7	0.92

n <sub>1</sub>	i	n <sub>2</sub>	M <sub>2</sub> (Nm)	kW <sub>1</sub>	HP <sub>1</sub>	RD	fs	P.A.M.
2800	26.47	106	914	11	15	0.92	2.07	38/300
	30.32	92	1047	11	15	0.92	1.33	38/300
	34.08	82	1176	11	15	0.92	1.53	38/300
	38.46	73	664	5.5	7.5	0.92	2.49	19/200
	41.49	67	1432	11	15	0.92	1.13	38/300
	47.25	59	815	5.5	7.5	0.92	1.71	28/250
	53.11	53	917	5.5	7.5	0.92	1.98	28/250
	59.60	47	1029	5.5	7.5	0.92	1.84	19/200
	64.66	43	1116	5.5	7.5	0.92	1.47	28/250
	73.22	38	1264	5.5	7.5	0.92	1.10	28/250
	93.42	30	1612	5.5	7.5	0.92	1.03	19/200
	105.79	26	1328	4	7.5	0.92	1.05	19/200

1400	26.47	53	2100	12.6	17.2	0.92
	30.32	46	1550	8.1	11.1	0.92
	34.08	41	2000	9.4	12.7	0.92
	38.46	36	1840	7.6	10.4	0.92
	41.49	34	1800	6.9	9.4	0.92
	47.25	30	1550	5.2	7.1	0.92
	53.11	26	2020	6.1	8.2	0.92
	59.60	23	2100	5.6	7.6	0.92
	64.66	22	1820	4.5	6.1	0.92
	73.22	19	1550	3.4	4.6	0.92
	93.42	15	1850	3.2	4.3	0.92
	105.79	13	1550	2.3	3.2	0.92

1400	26.47	53	1827	11	15	0.92	1.15	38/300
	30.32	46	1751	9.2	12.5	0.92	0.89	38/300
	34.08	41	1968	9.2	12.5	0.92	1.02	38/300
	38.46	36	965	4	5.5	0.92	1.91	19/200
	41.49	34	1432	5.5	7.5	0.92	1.26	38/300
	47.25	30	1188	4	5.5	0.92	1.31	28/250
	53.11	26	1333	4	5.5	0.92	1.52	28/250
	59.60	23	1496	4	5.5	0.92	1.40	19/200
	64.66	22	1623	4	5.5	0.92	1.12	28/250
	73.22	19	1379	3	4	0.92	1.12	28/250
	93.42	15	1759	3	4	0.92	1.05	19/200
	105.79	13	1461	2.2	3	0.92	1.06	19/200

900	26.47	34	2310	8.9	12.2	0.92
	30.32	30	1705	5.8	7.8	0.92
	34.08	26	2200	6.6	9.0	0.92
	38.46	23	2024	5.4	7.3	0.92
	41.49	22	1980	4.9	6.6	0.92
	47.25	19	1705	3.7	5.0	0.92
	53.11	17	2222	4.3	5.8	0.92
	59.60	15	2310	4.0	5.4	0.92
	64.66	14	2002	3.2	4.3	0.92
	73.22	12	1705	2.4	3.2	0.92
	93.42	10	2035	2.2	3.0	0.92
	105.79	9	1705	1.7	2.2	0.92

900	26.47	34	1421	5.5	7.5	0.92	1.63	38/300
	30.32	30	1628	5.5	7.5	0.92	1.05	38/300
	34.08	26	1830	5.5	7.5	0.92	1.20	38/300
	38.46	23	826	2.2	3	0.92	2.45	19/200
	41.49	22	1620	4	5.5	0.92	1.22	38/300
	47.25	19	1015	2.2	3	0.92	1.68	28/250
	53.11	17	1141	2.2	3	0.92	1.95	28/250
	59.60	15	1280	2.2	3	0.92	1.80	19/200
	64.66	14	1389	2.2	3	0.92	1.44	28/250
	73.22	12	1573	2.2	3	0.92	1.08	28/250
	93.42	10	2006	2.2	3	0.92	1.01	19/200
	105.79	9	1549	1.5	2	0.92	1.10	19/200

### DIMENSIONI D'INGOMBRO

### OVERALL DIMENSIONS

### ALLGEMEINE ABMESSUNGEN

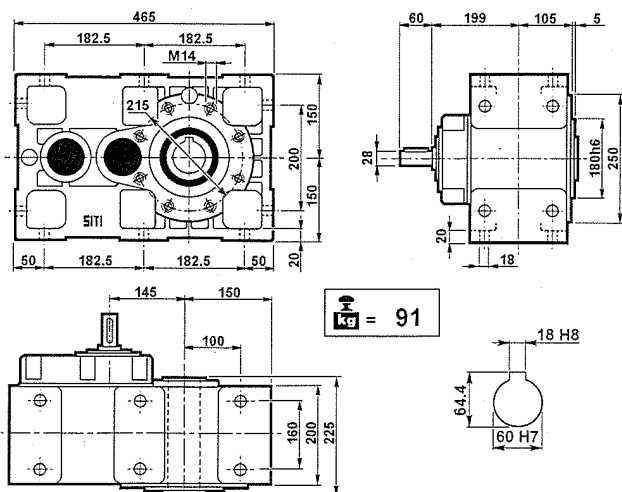

PL 125/3

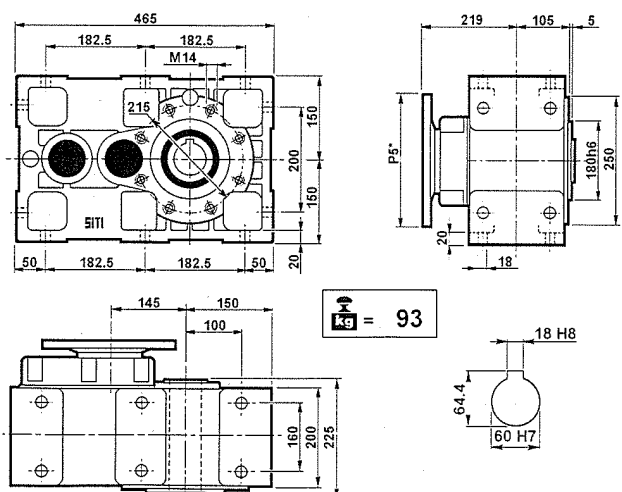

MPL 125/3

P<sub>5</sub>\* : Vedere i PAM per ogni singola versione  
P<sub>5</sub>\* : See PAM size for each single version  
P<sub>5</sub>\* : Siehe PAM Grösse für jede Ausführung

## PL 160

### PRESTAZIONI

### PERFORMANCES

### LEISTUNG

## MPL 160

n <sub>1</sub>	i	n <sub>2</sub>	M <sub>2</sub> (Nm)	kW <sub>1</sub>	HP <sub>1</sub>	RD
2800	9.87	284	2700	83.5	113.6	0.96
	12.74	220	2880	69.0	93.9	0.96
	15.54	180	2880	56.6	77.0	0.96
	16.27	172	3150	59.1	80.4	0.96
	19.87	141	2610	40.1	54.6	0.96
	21.01	133	3150	45.8	62.3	0.96
	25.62	109	2880	34.3	46.7	0.96
32.75	85	2700	25.2	34.2	0.96	

n <sub>1</sub>	i	n <sub>2</sub>	M <sub>2</sub> (Nm)	kW <sub>1</sub>	HP <sub>1</sub>	RD	fs	P.A.M.
2800	9.87	284	808	25	34	0.96	3.34	48/350 - 42/350
	12.74	220	1043	25	34	0.96	2.76	48/350 - 42/350
	15.54	180	1272	25	34	0.96	2.26	48/350 - 42/350
	16.27	172	1332	25	34	0.96	2.37	48/350 - 42/350
	19.87	141	1627	25	34	0.96	1.60	48/350 - 42/350
	21.01	133	1720	25	34	0.96	1.83	48/350 - 42/350
	25.62	109	2097	25	34	0.96	1.37	48/350 - 42/350
32.75	85	2681	25	34	0.96	1.01	48/350 - 42/350	

n <sub>1</sub>	i	n <sub>2</sub>	M <sub>2</sub> (Nm)	kW <sub>1</sub>	HP <sub>1</sub>	RD
1400	9.87	142	3000	46.4	63.1	0.96
	12.74	110	3200	38.4	52.2	0.96
	15.54	90	3200	31.4	42.8	0.96
	16.27	86	3500	32.8	44.7	0.96
	19.87	70	2900	22.3	30.3	0.96
	21.01	67	3500	25.4	34.6	0.96
	25.62	55	3200	19.1	25.9	0.96
32.75	43	3000	14.0	19.0	0.96	

n <sub>1</sub>	i	n <sub>2</sub>	M <sub>2</sub> (Nm)	kW <sub>1</sub>	HP <sub>1</sub>	RD	fs	P.A.M.
1400	9.87	142	1422	22	30	0.96	2.11	48/350 - 42/350
	12.74	110	1835	22	30	0.96	1.74	48/350 - 42/350
	15.54	90	2239	22	30	0.96	1.43	48/350 - 42/350
	16.27	86	2344	22	30	0.96	1.49	48/350 - 42/350
	19.87	70	2863	22	30	0.96	1.01	48/350 - 42/350
	21.01	87	3027	22	30	0.96	1.16	48/350 - 42/350
	25.62	55	3104	18.5	25	0.96	1.03	48/350 - 42/350
32.75	43	3217	15	20	0.96	0.93	48/350 - 42/350	

n <sub>1</sub>	i	n <sub>2</sub>	M <sub>2</sub> (Nm)	kW <sub>1</sub>	HP <sub>1</sub>	RD
900	9.87	91	3300	32.8	44.6	0.96
	12.74	71	3520	27.1	36.9	0.96
	15.54	58	3520	22.2	30.2	0.96
	16.27	55	3850	23.2	31.6	0.96
	19.87	45	3190	15.8	21.4	0.96
	21.01	43	3850	18.0	24.5	0.96
	25.62	35	3520	13.5	18.3	0.96
32.75	27	3300	9.9	13.5	0.96	

n <sub>1</sub>	i	n <sub>2</sub>	M <sub>2</sub> (Nm)	kW <sub>1</sub>	HP <sub>1</sub>	RD	fs	P.A.M.
900	9.87	91	1508	15	20	0.96	2.19	48/350 - 42/350
	12.74	71	1947	15	20	0.96	1.81	48/350 - 42/350
	15.54	58	2375	15	20	0.96	1.48	48/350 - 42/350
	16.27	55	2486	15	20	0.96	1.55	48/350 - 42/350
	19.87	45	3036	15	20	0.96	1.05	48/350 - 42/350
	21.01	43	3210	15	20	0.96	1.20	48/350 - 42/350
	25.62	35	2871	11	15	0.96	1.23	48/350 - 42/350
32.75	27	2502	7.5	10	0.96	1.32	48/350 - 42/350	

### DIMENSIONI D'INGOMBRO

### OVERALL DIMENSIONS

### ALLGEMEINE ABMESSUNGEN

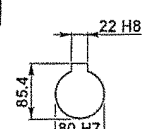
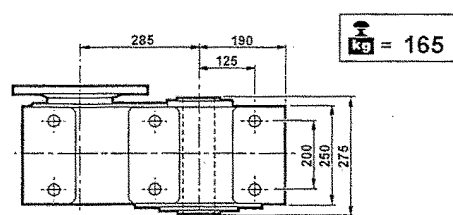
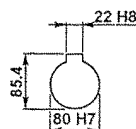
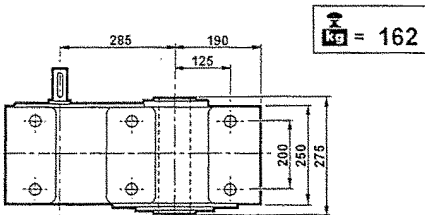
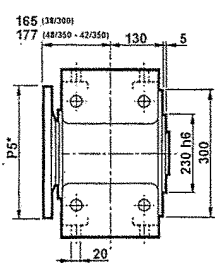
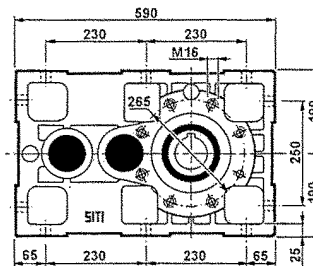
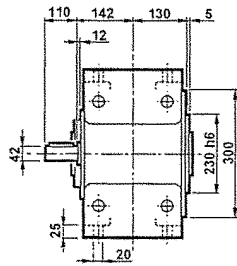
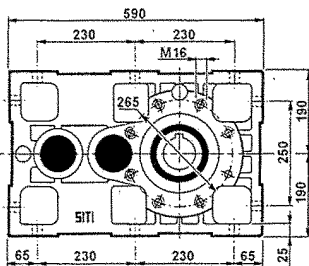

PL 160

MPL 160

P<sub>5</sub>\* : Vedere i PAM per ogni singola versione  
P<sub>5</sub>\* : See PAM size for each single version  
P<sub>5</sub>\* : Siehe PAM Grösse für jede Ausführung

### CARICHI RADIALI (N)

### OVERHUNG LOADS (N)

### RADIALE BELASTUNGEN (N)

ALBERO VELOCE / INPUT SHAFT / EINGANGSWELLE		
1400 min <sup>-1</sup>	PL 160	PL 160/3
	3200	2300

ALBERO LENTO / OUTPUT SHAFT / ABTRIEBSWELLE							
PL 160- PL 160/3							
min <sup>-1</sup>	0°	30°	60°	90°	120°	150°	180°
20	26910	27820	30190	33830	38010	41280	42570
40	20350	21270	23450	27090	31280	34729	36015
60	17280	18005	20190	23825	28010	31460	32915
80	15095	15825	18005	21645	25830	29465	30735
100	13640	14370	16365	19990	24180	27770	29280
120	12545	13095	15275	18735	23100	26735	28190
140	11640	12150	14173	17383	21434	24806	26156
160	10910	11388	13284	16293	20089	23251	24516

Rotazione oraria  
Clockwise  
rotation  
Uhrzeigersinn

Rotazione antioraria  
Anticlockwise  
rotation  
Gegenuhrzeigersinn

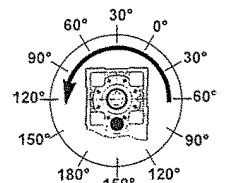
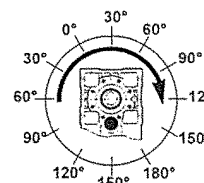

## PL 160/3

### PRESTAZIONI

### PERFORMANCES

### LEISTUNG

## MPL 160/3

n <sub>1</sub>	i	n <sub>2</sub>	M <sub>2</sub> (Nm)	kW <sub>1</sub>	HP <sub>1</sub>	RD
2800	34.24	82	3240	30.2	41.0	0.92
	39.47	71	2988	24.1	32.8	0.92
	41.78	67	3240	24.7	33.6	0.92
	50.46	55	2880	18.2	24.7	0.92
	53.36	52	3258	19.5	26.5	0.92
	58.57	48	3015	16.4	22.3	0.92
	65.07	43	3258	16.0	21.7	0.92
	71.52	39	2880	12.8	17.5	0.92
	75.63	37	3285	13.8	18.8	0.92
	83.19	34	2880	11.0	15.0	0.92
	92.23	30	3285	11.4	15.4	0.92
117.9	24	2880	7.8	10.6	0.92	

n <sub>1</sub>	i	n <sub>2</sub>	M <sub>2</sub> (Nm)	kW <sub>1</sub>	HP <sub>1</sub>	RD	fs	P.A.M.
2800	34.24	82	2686	25	34	0.92	1.21	48/350 - 42/350
	39.47	71	1362	11	15	0.92	2.19	38/300
	41.78	67	3276	25	34	0.92	0.99	48/350 - 42/350
	50.46	55	1742	11	15	0.92	1.65	38/300
	53.36	52	1842	11	15	0.92	1.77	38/300
	58.57	48	1011	5.5	7.5	0.92	2.98	28/250
	65.07	43	2246	11	15	0.92	1.45	38/300
	71.52	39	1234	5.5	7.5	0.92	2.33	28/250
	75.63	37	1305	5.5	7.5	0.92	2.52	28/250
	83.19	34	2871	11	15	0.92	1.00	38/300
	92.23	30	1592	5.5	7.5	0.92	2.06	28/250
117.9	24	2035	5.5	7.5	0.92	1.42	28/250	

n <sub>1</sub>	i	n <sub>2</sub>	M <sub>2</sub> (Nm)	kW <sub>1</sub>	HP <sub>1</sub>	RD
1400	34.24	41	3600	16.8	22.8	0.92
	39.47	35	3320	13.4	18.2	0.92
	41.78	34	3600	13.7	18.7	0.92
	50.46	28	3200	10.1	13.7	0.92
	53.36	26	3620	10.8	14.7	0.92
	58.57	24	3350	9.1	12.4	0.92
	65.07	22	3620	8.9	12.1	0.92
	71.52	20	3200	7.1	9.7	0.92
	75.63	19	3650	7.7	10.5	0.92
	83.19	17	3200	6.1	8.3	0.92
	92.23	15	3650	6.3	8.6	0.92
117.9	12	3200	4.3	5.9	0.92	

n <sub>1</sub>	i	n <sub>2</sub>	M <sub>2</sub> (Nm)	kW <sub>1</sub>	HP <sub>1</sub>	RD	fs	P.A.M.
1400	34.24	41	3223	10	20	0.92	1.12	48/350 - 42/350
	39.47	35	2725	11	15	0.92	1.22	38/300
	41.78	34	3931	15	20	0.92	0.92	48/350 - 42/350
	50.46	28	2913	9.2	12.5	0.92	1.10	38/300
	53.36	26	3081	9.2	12.5	0.92	1.18	38/300
	58.57	24	1470	4	5.5	0.92	2.28	28/250
	65.07	22	3063	7.5	10	0.92	1.18	38/300
	71.52	20	1795	4	5.5	0.92	1.78	28/250
	75.63	19	1899	4	5.5	0.92	1.92	28/250
	83.19	17	2871	5.5	7.5	0.92	1.11	38/300
	92.23	15	2315	4	5.5	0.92	1.58	28/250
117.9	12	2960	4	5.5	0.92	1.08	28/250	

n <sub>1</sub>	i	n <sub>2</sub>	M <sub>2</sub> (Nm)	kW <sub>1</sub>	HP <sub>1</sub>	RD
900	34.24	26	3960	11.8	16.1	0.92
	39.47	23	3652	9.5	12.9	0.92
	41.78	22	3960	9.7	13.2	0.92
	50.46	18	3520	7.1	9.7	0.92
	53.36	17	3982	7.6	10.4	0.92
	58.57	15	3685	6.4	8.8	0.92
	65.07	14	3982	6.3	8.5	0.92
	71.52	13	3520	5.0	6.9	0.92
	75.63	12	4015	5.4	7.4	0.92
	83.19	11	3520	4.3	5.9	0.92
	92.23	10	4015	4.5	6.1	0.92
117.9	8	3520	3.1	4.2	0.92	

n <sub>1</sub>	i	n <sub>2</sub>	M <sub>2</sub> (Nm)	kW <sub>1</sub>	HP <sub>1</sub>	RD	fs	P.A.M.
900	34.24	26	3677	11	15	0.92	1.08	48/350 - 42/350
	39.47	23	2119	5.5	7.5	0.92	1.72	38/300
	41.78	22	3058	7.5	10	0.92	1.30	48/350 - 42/350
	50.46	18	2709	5.5	7.5	0.92	1.30	38/300
	53.36	17	2865	5.5	7.5	0.92	1.39	38/300
	58.57	15	1258	2.2	3	0.92	2.93	28/250
	65.07	14	3494	5.5	7.5	0.92	1.14	38/300
	71.52	13	1536	2.2	3	0.92	2.29	28/250
	75.63	12	1624	2.2	3	0.92	2.47	28/250
	83.19	11	3248	4	5.5	0.92	1.08	38/300
	92.23	10	1981	2.2	3	0.92	2.03	28/250
117.9	8	2532	2.2	3	0.92	1.39	28/250	

### DIMENSIONI D'INGOMBRO

### OVERALL DIMENSIONS

### ALLGEMEINE ABMESSUNGEN

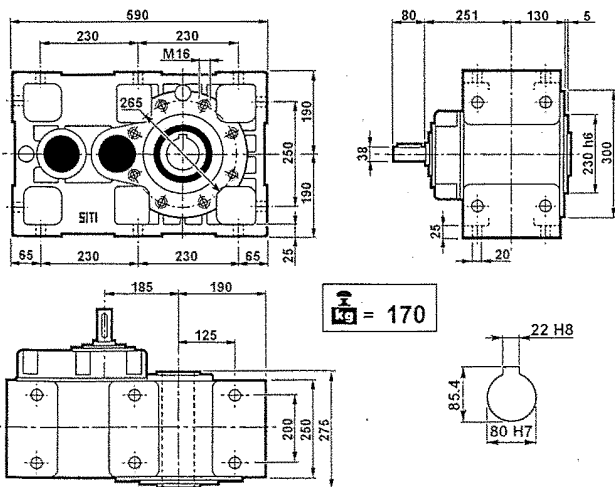

PL 160/3

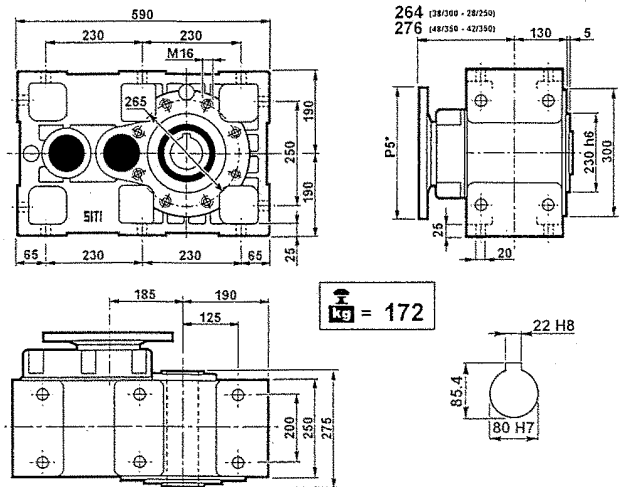

MPL 160/3

P<sub>5</sub>\* : Vedere i PAM per ogni singola versione  
P<sub>5</sub>\* : See PAM size for each single version  
P<sub>5</sub>\* : Siehe PAM Grösse für jede Ausführung



## PD 63

### PRESTAZIONI

### PERFORMANCES

### LEISTUNG

## MPD 63

n <sub>1</sub>	i	n <sub>2</sub>	M <sub>2</sub> (Nm)	kW <sub>1</sub>	HP <sub>1</sub>	RD
2800	10.60	264	180	5.2	7.1	0.96
	13.65	205	180	4.0	5.5	0.96
	15.01	187	180	3.7	5.0	0.96
	17.97	156	216	3.7	5.0	0.96
	18.71	150	153	2.5	3.4	0.96
	23.12	121	207	2.7	3.7	0.96
	25.42	110	207	2.5	3.4	0.96
31.69	88	162	1.6	2.1	0.96	
1400	10.60	132	200	2.9	3.9	0.96
	13.65	103	200	2.2	3.0	0.96
	15.01	93	200	2.0	2.8	0.96
	17.97	78	240	2.0	2.8	0.96
	18.71	75	170	1.4	1.9	0.96
	23.12	61	230	1.5	2.1	0.96
	25.42	55	230	1.4	1.9	0.96
31.69	44	180	0.9	1.2	0.96	
900	10.60	85	220	2.0	2.8	0.96
	13.65	66	220	1.6	2.2	0.96
	15.01	60	220	1.4	2.0	0.96
	17.97	50	264	1.4	2.0	0.96
	18.71	48	187	1.0	1.3	0.96
	23.12	39	253	1.1	1.5	0.96
	25.42	35	253	1.0	1.3	0.96
31.69	28	198	0.6	0.8	0.96	

n <sub>1</sub>	i	n <sub>2</sub>	M <sub>2</sub> (Nm)	kW <sub>1</sub>	HP <sub>1</sub>	RD	fs	P.A.M.
2800	10.60	264	76	2.2	3	0.96	2.36	24/200 - 19/200
	13.65	205	98	2.2	3	0.96	1.83	24/200 - 19/200
	15.01	187	108	2.2	3	0.96	1.66	24/200 - 19/200
	17.97	156	129	2.2	3	0.96	1.67	24/200 - 19/200
	18.71	150	135	2.2	3	0.96	1.14	24/200 - 19/200
	23.12	121	167	2.2	3	0.96	1.24	24/200 - 19/200
	25.42	110	125	1.5	2	0.96	1.66	24/200 - 19/200
31.69	88	156	1.5	2	0.96	1.04	24/200 - 19/200	
1400	10.60	132	125	1.8	2.5	0.96	1.60	24/200 - 19/200
	13.65	103	161	1.8	2.5	0.96	1.24	24/200 - 19/200
	15.01	93	177	1.8	2.5	0.96	1.13	24/200 - 19/200
	17.97	78	212	1.8	2.5	0.96	1.13	24/200 - 19/200
	18.71	75	184	1.5	2.0	0.96	0.92	24/200 - 19/200
	23.12	61	227	1.5	2.0	0.96	1.01	24/200 - 19/200
	25.42	55	183	1.1	1.5	0.96	1.26	24/200 - 19/200
31.69	44	156	0.75	1.0	0.96	1.16	24/200 - 19/200	
900	10.60	85	119	1.1	1.5	0.96	1.85	24/200 - 19/200
	13.65	66	153	1.1	1.5	0.96	1.44	24/200 - 19/200
	15.01	60	168	1.1	1.5	0.96	1.31	24/200 - 19/200
	17.97	50	201	1.1	1.5	0.96	1.31	24/200 - 19/200
	18.71	48	210	1.1	1.5	0.96	0.89	24/200 - 19/200
	23.12	40	259	1.1	1.5	0.96	0.98	24/200 - 19/200
	25.42	35	194	0.75	1.0	0.96	1.30	24/200 - 19/200
31.69	28	178	0.55	0.75	0.96	1.12	24/200 - 19/200	

### DIMENSIONI D'INGOMBRO

### OVERALL DIMENSIONS

### ALLGEMEINE ABMESSUNGEN

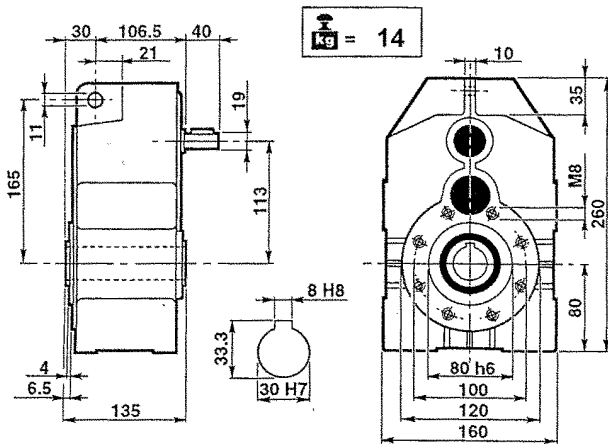

PD 63

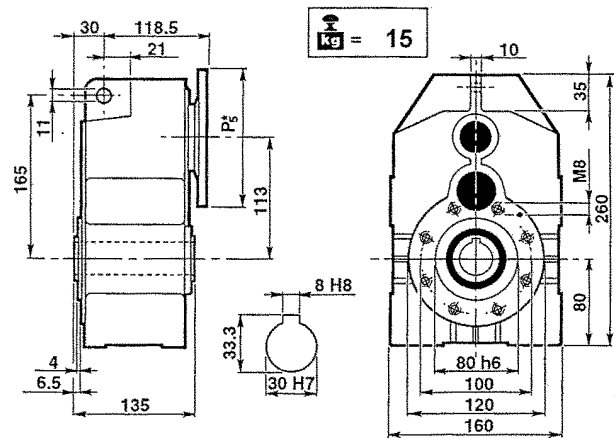

MPD 63

P<sub>5</sub>\* : Vedere i PAM per ogni singola versione  
P<sub>5</sub>\* : See PAM size for each single version  
P<sub>5</sub>\* : Siehe PAM Grösse für jede Ausführung

### CARICHI RADIALI (N)

### OVERHUNG LOADS (N)

### RADIALE BELASTUNGEN (N)

ALBERO VELOCE / INPUT SHAFT / EINGANGSWELLE		
1400 min <sup>-1</sup>	PD 63	PD 63/3
	650	400

ALBERO LENTO / OUTPUT SHAFT / ABTRIEBSWELLE								
PD 63 - PD 63/3								
min <sup>-1</sup>	0°	30°	60°	90°	120°	150°	180°	
20	9205	9517	10327	11572	13002	14121	14562	
40	6961	7276	8022	9267	10700	11880	12320	
60	5911	6159	6907	8150	9582	10762	11259	
80	5164	5413	6159	7404	8836	10079	10514	
100	4666	4916	5598	6838	8271	9500	10016	
120	4291	4480	5225	6409	7902	9145	9643	
140	3982	4156	4848	5946	7332	8486	8948	
160	3732	3896	4544	5574	6872	7954	8386	

Rotazione oraria  
Clockwise rotation  
Uhrzeigersinn

Rotazione antioraria  
Anticlockwise rotation  
Gegenuhrzeigersinn

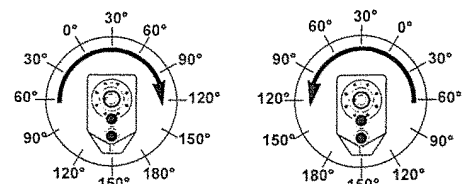

## PD 63/3

### PRESTAZIONI

### PERFORMANCES

### LEISTUNG

## MPD 63/3

$n_1$	$i$	$n_2$	$M_2$ (Nm)	$kW_1$	$HP_1$	RD
2800	29.25	96	252	2.7	3.7	0.92
	37.68	74	270	2.3	3.1	0.92
	41.43	68	252	1.9	2.6	0.92
	47.53	59	180	1.2	1.6	0.92
	51.66	54	198	1.2	1.7	0.92
	58.72	48	270	1.5	2.0	0.92
	64.55	43	252	1.2	1.7	0.92
	67.37	42	198	0.9	1.3	0.92
	80.5	35	198	0.8	1.1	0.92
	83.22	34	270	1.0	1.4	0.92
	91.49	31	252	0.9	1.2	0.92
	114.09	25	198	0.6	0.8	0.92

$n_1$	$i$	$n_2$	$M_2$ (Nm)	$kW_1$	$HP_1$	RD	$f_s$	P.A.M.
2800	29.25	96	138	1.50	2	0.92	1.83	19/200 - 14/160
	37.68	74	177	1.50	2	0.92	1.52	19/200 - 14/160
	41.43	66	195	1.50	2	0.92	1.29	19/200 - 14/160
	47.53	59	112	0.75	1	0.92	1.61	14/160
	51.66	54	178	1.10	1.5	0.92	1.11	19/200 - 14/160
	58.72	48	138	0.75	1	0.92	1.95	14/160
	64.55	43	152	0.75	1	0.92	1.66	14/160
	67.37	42	53	0.25	0.34	0.92	3.75	11/140
	80.5	35	189	0.75	1	0.92	1.05	14/160
	83.22	34	65	0.25	0.34	0.92	4.14	11/140
	91.49	31	72	0.25	0.34	0.92	3.51	11/140
	114.09	25	89	0.25	0.34	0.92	2.21	11/140

1400	29.25	48	280	1.5	2.1	0.92
	37.68	37	300	1.3	1.7	0.92
	41.43	34	280	1.1	1.5	0.92
	47.53	29	200	0.7	0.9	0.92
	51.66	27	220	0.7	0.9	0.92
	58.72	24	300	0.8	1.1	0.92
	64.55	22	280	0.7	0.9	0.92
	67.37	21	220	0.5	0.7	0.92
	80.5	17	220	0.4	0.6	0.92
	83.22	17	300	0.6	0.8	0.92
	91.49	15	280	0.5	0.7	0.92
	114.09	12	220	0.3	0.4	0.92

1400	29.25	48	138	0.75	1	0.92	2.03	19/200 - 14/160
	37.68	37	177	0.75	1	0.92	1.69	19/200 - 14/160
	41.43	34	195	0.75	1	0.92	1.44	19/200 - 14/160
	47.53	29	110	0.37	0.5	0.92	1.81	14/160
	51.66	27	243	0.75	1	0.92	0.90	19/200 - 14/160
	58.72	24	136	0.37	0.5	0.92	2.20	14/160
	64.55	22	150	0.37	0.5	0.92	1.87	14/160
	67.37	21	76	0.18	0.25	0.92	2.89	11/140
	80.5	17	187	0.37	0.50	0.92	1.18	14/160
	83.22	17	94	0.18	0.25	0.92	3.19	11/140
	91.49	15	103	0.18	0.25	0.92	2.71	11/140
	114.09	12	129	0.18	0.25	0.92	1.71	11/140

900	29.25	31	308	1.1	1.5	0.92
	37.68	24	330	0.9	1.2	0.92
	41.43	22	308	0.8	1.0	0.92
	47.53	19	220	0.5	0.6	0.92
	51.66	17	242	0.5	0.7	0.92
	58.72	15	330	0.6	0.8	0.92
	64.55	14	308	0.5	0.7	0.92
	67.37	13	242	0.4	0.5	0.92
	80.5	11	242	0.3	0.4	0.92
	83.22	11	330	0.4	0.6	0.92
	91.49	10	308	0.3	0.5	0.92
	114.09	8	242	0.2	0.3	0.92

900	29.25	31	157	0.55	0.75	0.92	1.96	19/200 - 14/160
	37.68	24	202	0.55	0.75	0.92	1.63	19/200 - 14/160
	41.43	22	222	0.55	0.75	0.92	1.38	19/200 - 14/160
	47.53	19	216	0.25	0.34	0.92	1.90	14/160
	51.66	17	277	0.55	0.75	0.92	0.87	19/200 - 14/160
	58.72	15	143	0.25	0.34	0.92	2.30	14/160
	64.55	14	158	0.25	0.34	0.92	1.96	14/160
	67.37	13	79	0.12	0.16	0.92	3.07	11/140
	80.5	11	196	0.25	0.34	0.92	1.23	14/160
	83.22	11	97	0.12	0.16	0.92	3.8	11/140
	91.49	10	107	0.12	0.16	0.92	2.87	11/140
	114.09	8	134	0.12	0.16	0.92	1.81	11/140

### DIMENSIONI D'INGOMBRO

### OVERALL DIMENSIONS

### ALLGEMEINE ABMESSUNGEN

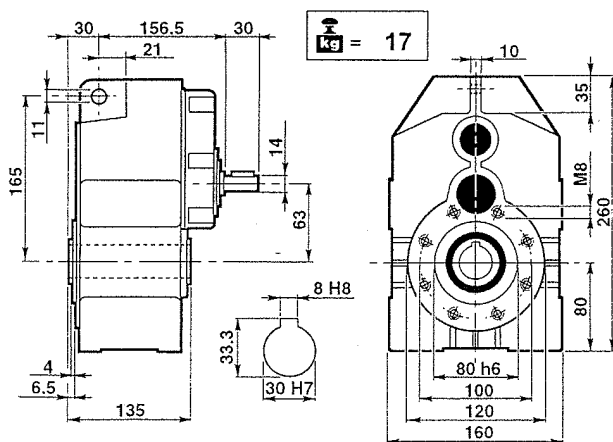

PD 63/3

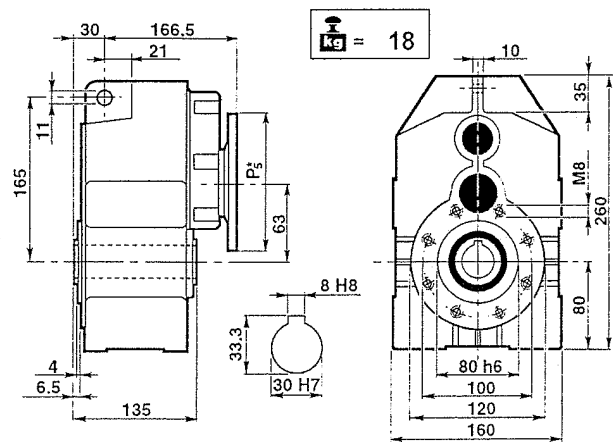

MPD 63/3

$P_5^*$  : Vedere i PAM per ogni singola versione  
 $P_5^*$  : See PAM size for each single version  
 $P_5^*$  : Siehe PAM Grösse für jede Ausführung

## PD 80

### PRESTAZIONI

### PERFORMANCES

### LEISTUNG

## MPD 80

n <sub>1</sub>	i	n <sub>2</sub>	M <sub>2</sub> (Nm)	kW <sub>1</sub>	HP <sub>1</sub>	RD
2800	10.02	279	360	11.0	14.9	0.96
	12.94	216	360	8.5	11.6	0.96
	15.78	177	360	7.0	9.5	0.96
	17.95	156	441	7.5	10.2	0.96
	20.17	139	405	6.1	8.3	0.96
	23.17	121	378	5.0	6.8	0.96
	28.26	99	378	4.1	5.6	0.96
36.13	77	360	3.0	4.1	0.96	
1400	10.02	140	400	6.1	8.3	0.96
	12.94	108	400	4.7	6.4	0.96
	15.78	89	400	3.9	5.3	0.96
	17.95	78	490	4.2	5.7	0.96
	20.17	69	450	3.4	4.6	0.96
	23.17	60	420	2.8	3.8	0.96
	28.26	50	420	2.3	3.1	0.96
36.13	39	400	1.7	2.3	0.96	
900	10.02	90	440	4.3	5.9	0.96
	12.94	70	440	3.3	4.5	0.96
	15.78	57	440	2.7	3.7	0.96
	17.95	50	539	2.9	4.0	0.96
	20.17	45	495	2.4	3.3	0.96
	23.17	39	462	2.0	2.7	0.96
	28.26	32	462	1.6	2.2	0.96
36.13	25	440	1.2	1.6	0.96	

n <sub>1</sub>	i	n <sub>2</sub>	M <sub>2</sub> (Nm)	kW <sub>1</sub>	HP <sub>1</sub>	RD	fs	P.A.M.
2800	10.02	279	180	5.5	7.5	0.96	2.00	28/250 - 24/200
	12.94	216	233	5.5	7.5	0.96	1.54	28/250 - 24/200
	15.78	177	284	5.5	7.5	0.96	1.27	28/250 - 24/200
	17.95	156	323	5.5	7.5	0.96	1.36	28/250 - 24/200
	20.17	139	363	5.5	7.5	0.96	1.11	28/250 - 24/200
	23.17	121	303	4.0	5.5	0.96	1.25	28/250 - 24/200
	28.26	99	370	4.0	5.5	0.96	1.02	28/250 - 24/200
36.13	77	260	2.2	3.0	0.96	1.38	28/250 - 24/200	
1400	10.02	140	262	4.0	5.5	0.96	1.52	28/250 - 24/200
	12.94	108	339	4.0	5.5	0.96	1.18	28/250 - 24/200
	15.78	89	310	3.0	4.0	0.96	1.29	28/250 - 24/200
	17.95	78	470	4.0	5.5	0.96	1.04	28/250 - 24/200
	20.17	69	396	3.0	4.0	0.96	1.14	28/250 - 24/200
	23.17	60	334	2.2	3.0	0.96	1.26	28/250 - 24/200
	28.26	49	407	2.2	3.0	0.96	1.03	28/250 - 24/200
36.13	39	365	1.5	2.0	0.96	1.13	28/250 - 24/200	
900	10.02	90	225	2.2	3.0	0.96	1.96	28/250 - 24/200
	12.94	70	290	2.2	3.0	0.96	1.52	28/250 - 24/200
	15.78	57	354	2.2	3.0	0.96	1.24	28/250 - 24/200
	17.95	50	402	2.2	3.0	0.96	1.34	28/250 - 24/200
	20.17	45	452	2.2	3.0	0.96	1.10	28/250 - 24/200
	23.17	39	354	1.5	2.0	0.96	1.30	28/250 - 24/200
	28.26	32	432	1.5	2.0	0.96	1.07	28/250 - 24/200
36.13	25	405	1.1	1.5	0.96	1.09	28/250 - 24/200	

### DIMENSIONI D'INGOMBRO

### OVERALL DIMENSIONS

### ALLGEMEINE ABMESSUNGEN

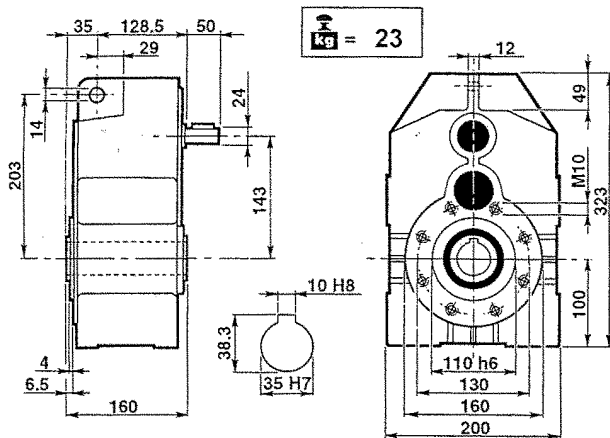

PD 80

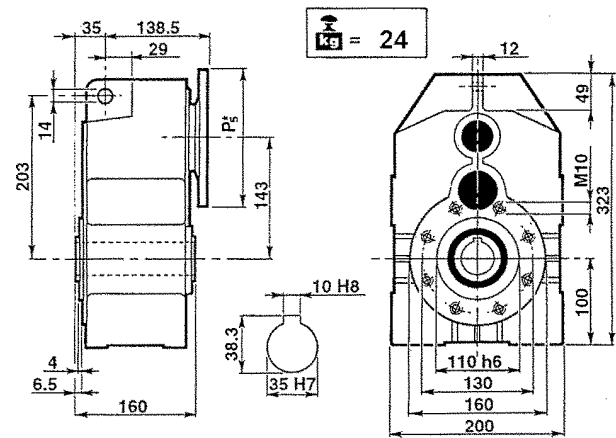

MPD 80

P<sub>5</sub>\* : Vedere i PAM per ogni singola versione

P<sub>5</sub>\* : See PAM size for each single version

P<sub>5</sub>\* : Siehe PAM Größe für jede Ausführung

### CARICHI RADIALI (N)

### OVERHUNG LOADS (N)

### RADIALE BELASTUNGEN (N)

ALBERO VELOCE / INPUT SHAFT / EINGANGSWELLE		
1400 min <sup>-1</sup>	PD 80	PD 80/3
	900	650

ALBERO LENTO / OUTPUT SHAFT / ABTRIEBSWELLE								
PD 80 - PD 80/3								
min <sup>-1</sup>	0°	30°	60°	90°	120°	150°	180°	
20	9995	10333	11213	12565	14118	15332	15811	
40	7558	7900	8710	10062	11618	12899	13377	
60	6418	6687	7499	8849	10403	11685	12225	
80	5607	5878	6687	8039	9594	10944	11416	
100	5066	5337	6078	7425	8981	10314	10375	
120	4659	4864	5673	6959	8580	9930	10470	
140	4323	4513	5264	6457	7961	9214	9715	
160	4052	4230	4934	6052	7462	8636	9106	

Rotazione oraria  
Clockwise  
rotation  
Uhrzeigersinn

Rotazione antioraria  
Anticlockwise  
rotation  
Gegenuhrzeigersinn

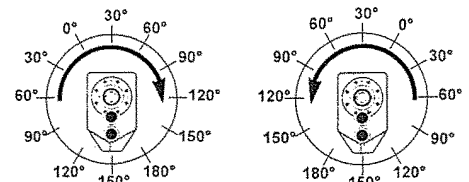

## PD 80/3

### PRESTAZIONI

### PERFORMANCES

### LEISTUNG

## MPD 80/3

n <sub>1</sub>	i	n <sub>2</sub>	M <sub>2</sub> (Nm)	kW <sub>1</sub>	HP <sub>1</sub>	RD
2800	24.45	115	459	6.0	8.1	0.92
	31.57	89	459	4.6	6.3	0.92
	38.47	73	450	3.7	5.1	0.92
	46.91	60	432	2.9	4.0	0.92
	49.22	57	360	2.3	3.2	0.92
	56.54	50	459	2.6	3.5	0.92
	59.97	47	360	1.9	2.6	0.92
	68.95	41	441	2.0	2.8	0.92
	84.58	33	468	1.8	2.4	0.92
	88.15	32	378	1.4	1.9	0.92
	103.15	27	450	1.4	1.9	0.92
	131.86	21	378	0.9	1.2	0.92

n <sub>1</sub>	i	n <sub>2</sub>	M <sub>2</sub> (Nm)	kW <sub>1</sub>	HP <sub>1</sub>	RD	P.A.M.	
2800	24.45	115	169	2.2	3	0.92	2.72	24/200 - 19/200
	31.57	89	218	2.2	3	0.92	2.11	24/200 - 19/200
	38.47	73	362	3.0	4	0.92	1.24	28/250 - 24/200
	46.91	60	442	3.0	4	0.92	0.98	28/250 - 24/200
	49.22	57	340	2.2	3	0.92	1.06	24/200 - 19/200
	56.54	50	390	2.2	3	0.92	1.18	24/200 - 19/200
	59.97	47	282	1.5	2	0.92	1.28	28/250 - 24/200
	68.95	41	325	1.5	2	0.92	1.36	24/200 - 19/200
	84.58	33	199	0.75	1	0.92	2.35	14/160
	88.15	32	304	1.1	1.5	0.92	1.24	24/200 - 19/200
	103.15	27	243	0.75	1	0.92	1.85	14/160
	131.86	21	310	0.75	1	0.92	1.22	14/160

n <sub>1</sub>	i	n <sub>2</sub>	M <sub>2</sub> (Nm)	kW <sub>1</sub>	HP <sub>1</sub>	RD
1400	24.45	57	510	3.3	4.5	0.92
	31.57	44	510	2.6	3.5	0.92
	38.47	36	500	2.1	2.8	0.92
	46.91	30	480	1.6	2.2	0.92
	49.22	28	400	1.3	1.8	0.92
	56.54	25	510	1.4	2.0	0.92
	59.97	23	400	1.1	1.4	0.92
	68.95	20	490	1.1	1.5	0.92
	84.58	17	520	1.0	1.3	0.92
	88.15	16	420	0.8	1.0	0.92
	103.15	14	500	0.8	1.1	0.92
	131.86	11	420	0.5	0.7	0.92

n <sub>1</sub>	i	n <sub>2</sub>	M <sub>2</sub> (Nm)	kW <sub>1</sub>	HP <sub>1</sub>	RD	P.A.M.	
1400	24.45	57	276	1.8	2.5	0.92	1.85	24/200 - 19/200
	31.57	44	357	1.8	2.5	0.92	1.43	24/200 - 19/200
	38.47	36	531	2.2	3.0	0.92	0.94	28/250 - 24/200
	46.91	30	442	1.5	2.0	0.92	1.09	28/250 - 24/200
	49.22	28	340	1.1	1.5	0.92	1.18	24/200 - 19/200
	56.54	25	390	1.1	1.5	0.92	1.31	24/200 - 19/200
	59.97	23	414	1.1	1.5	0.92	0.97	28/250 - 24/200
	68.95	20	476	1.1	1.5	0.92	1.03	24/200 - 19/200
	84.58	17	196	0.37	0.5	0.92	2.65	14/160
	88.15	16	415	0.75	1.0	0.92	1.01	24/200 - 19/200
	103.15	14	240	0.37	0.5	0.92	2.09	14/160
	131.86	11	306	0.37	0.5	0.92	1.37	14/160

n <sub>1</sub>	i	n <sub>2</sub>	M <sub>2</sub> (Nm)	kW <sub>1</sub>	HP <sub>1</sub>	RD
900	24.45	37	561	2.4	3.2	0.92
	31.57	29	561	1.8	2.5	0.92
	38.47	23	550	1.5	2.0	0.92
	46.91	19	528	1.2	1.6	0.92
	49.22	18	440	0.9	1.2	0.92
	56.54	16	561	1.0	1.4	0.92
	59.97	15	440	0.8	1.0	0.92
	68.95	13	539	0.8	1.1	0.92
	84.58	11	572	0.7	0.9	0.92
	88.15	10	462	0.5	0.7	0.92
	103.15	9	550	0.5	0.7	0.92
	131.86	7	462	0.4	0.5	0.92

n <sub>1</sub>	i	n <sub>2</sub>	M <sub>2</sub> (Nm)	kW <sub>1</sub>	HP <sub>1</sub>	RD	P.A.M.	
900	24.45	37	263	1.1	1.5	0.92	2.14	24/200 - 19/200
	31.57	29	339	1.1	1.5	0.92	1.65	24/200 - 19/200
	38.47	23	563	1.5	2.0	0.92	0.98	28/250 - 24/200
	46.91	19	504	1.1	1.5	0.92	1.05	28/250 - 24/200
	49.22	18	360	0.75	1.0	0.92	1.22	24/200 - 19/200
	56.54	16	414	0.75	1.0	0.92	1.36	24/200 - 19/200
	59.97	15	439	0.75	1.0	0.92	1.00	28/250 - 24/200
	68.95	13	505	0.75	1.0	0.92	1.07	24/200 - 19/200
	84.58	11	206	0.25	0.34	0.92	2.77	14/160
	88.15	10	473	0.55	0.75	0.92	0.89	24/200 - 19/200
	103.15	9	252	0.25	0.34	0.92	2.18	14/160
	131.86	7	322	0.25	0.34	0.92	1.44	14/160

### DIMENSIONI D'INGOMBRO

### OVERALL DIMENSIONS

### ALLGEMEINE ABMESSUNGEN

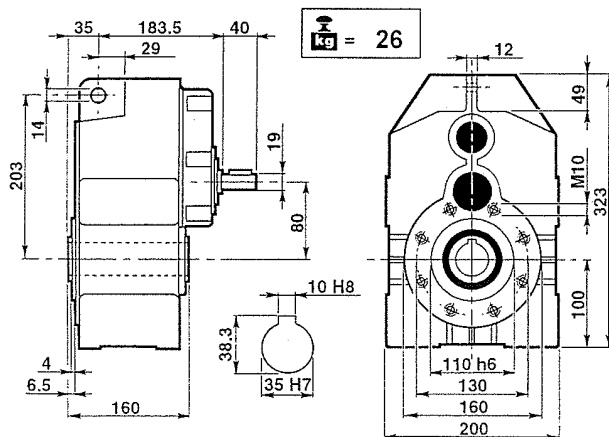

PD 80/3

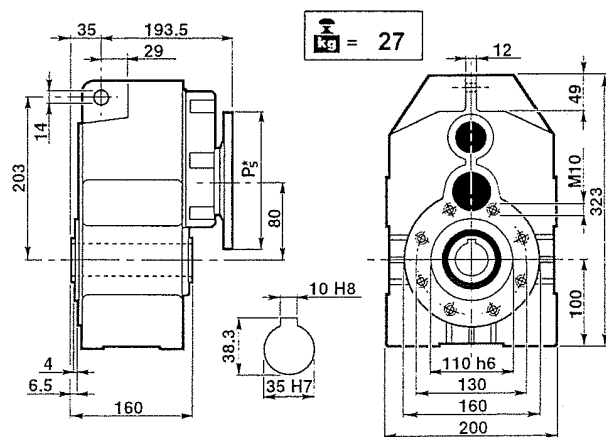

MPD 80/3

P<sub>5</sub>\* : Vedere i PAM per ogni singola versione  
P<sub>5</sub>\* : See PAM size for each single version  
P<sub>5</sub>\* : Siehe PAM Grösse für jede Ausführung

## PD 100

### PRESTAZIONI

n <sub>1</sub>	i	n <sub>2</sub>	M <sub>2</sub> (Nm)	kW <sub>1</sub>	HP <sub>1</sub>	RD
2800	9.98	281	720	22.0	30.0	0.96
	12.89	217	720	17.1	23.2	0.96
	15.47	181	855	16.9	23.0	0.96
	15.72	178	720	14.0	19.0	0.96
	19.98	140	810	12.4	16.8	0.96
	20.49	137	675	10.1	13.7	0.96
	24.36	115	810	10.2	13.8	0.96
31.75	88	675	6.5	8.8	0.96	
1400	9.98	140	800	12.2	16.6	0.96
	12.89	109	800	9.5	12.9	0.96
	15.47	90	950	9.4	12.8	0.96
	15.72	89	800	7.8	10.6	0.96
	19.98	70	900	6.9	9.4	0.96
	20.49	68	750	5.6	7.6	0.96
	24.36	57	900	5.6	7.7	0.96
31.75	44	750	3.6	4.9	0.96	
900	9.98	90	880	8.7	11.8	0.96
	12.89	70	880	6.7	9.1	0.96
	15.47	58	1045	6.6	9.0	0.96
	15.72	57	880	5.5	7.5	0.96
	19.98	45	990	4.9	6.6	0.96
	20.49	44	825	4.0	5.4	0.96
	24.36	37	990	4.0	5.4	0.96
31.75	28	825	2.6	3.5	0.96	

### PERFORMANCES

### LEISTUNG

## MPD 100

n <sub>1</sub>	i	n <sub>2</sub>	M <sub>2</sub> (Nm)	kW <sub>1</sub>	HP <sub>1</sub>	RD	fs	P.A.M.
2800	9.98	281	359	11	15	0.96	2.01	38/300 - 28/250
	12.89	217	464	11	15	0.96	1.55	38/300 - 28/250
	15.47	178	557	11	15	0.96	1.54	38/300 - 28/250
	15.72	137	566	11	15	0.96	1.27	38/300 - 28/250
	19.98	181	720	11	15	0.96	1.13	38/300 - 28/250
	20.49	140	604	9	12.5	0.96	1.12	38/300 - 28/250
	24.36	115	718	9	12.5	0.96	1.13	38/300 - 28/250
31.75	88	672	5.5	7.5	0.96	1.18	38/300 - 28/250	
1400	9.98	140	719	11	15	0.96	1.11	38/300 - 28/250
	12.89	109	777	9.2	12.5	0.96	1.03	38/300 - 28/250
	15.47	90	932	9.2	12.5	0.96	1.02	38/300 - 28/250
	15.72	89	772	7.5	10	0.96	1.04	38/300 - 28/250
	19.98	70	720	5.5	7.5	0.96	1.25	38/300 - 28/250
	20.49	68	738	5.5	7.5	0.96	1.02	38/300 - 28/250
	24.36	57	877	5.5	7.5	0.96	1.03	38/300 - 28/250
31.75	44	624	3.0	4	0.96	1.20	38/300 - 28/250	
900	9.98	90	559	5.5	7.5	0.96	1.57	38/300 - 28/250
	12.89	70	722	5.5	7.5	0.96	1.22	38/300 - 28/250
	15.47	58	867	5.5	7.5	0.96	1.21	38/300 - 28/250
	15.72	57	881	5.5	7.5	0.96	1.00	38/300 - 28/250
	19.98	45	814	4.0	5.5	0.96	1.22	38/300 - 28/250
	20.49	44	835	4.0	5.5	0.96	0.99	38/300 - 28/250
	24.36	37	993	4.0	5.5	0.96	1.00	38/300 - 28/250
31.75	28	712	2.2	3.0	0.96	1.16	38/300 - 28/250	

### DIMENSIONI D'INGOMBRO

### OVERALL DIMENSIONS

### ALLGEMEINE ABMESSUNGEN

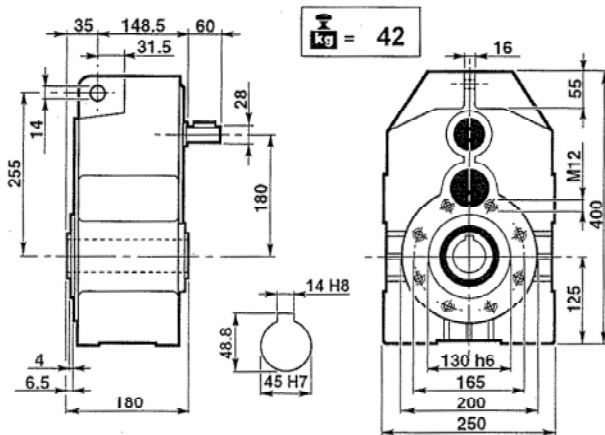

PD 100

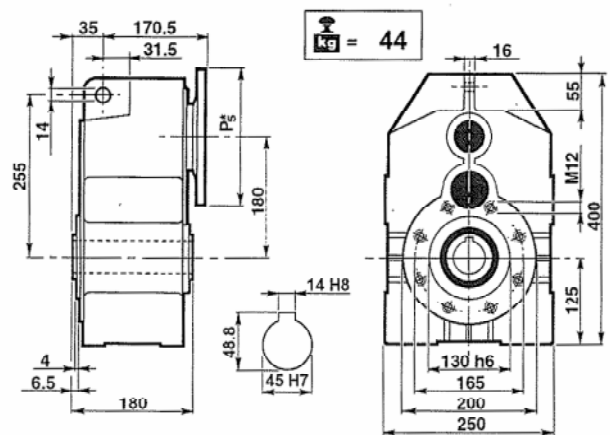

MPD 100

P<sub>5</sub>\* : Vedere i PAM per ogni singola versione  
P<sub>5</sub>\* : See PAM size for each single version  
P<sub>5</sub>\* : Siehe PAM Grösse für jede Ausführung

### CARICHI RADIALI (N)

### OVERHUNG LOADS (N)

### RADIALE BELASTUNGEN (N)

ALBERO VELOCE / INPUT SHAFT / EINGANGSWELLE							
1400 min <sup>-1</sup>	PD 100			PD 100/3			
	1400						
ALBERO LENTO / OUTPUT SHAFT / ABTRIEBSWELLE							
PD 100 - PD 100/3							
min <sup>-1</sup>	0°	30°	60°	90°	120°	150°	180°
20	13186	13632	14793	16577	18625	20227	20859
40	9972	10422	11491	13274	15327	17017	17646
60	8467	8822	9893	11674	13725	15415	16128
80	7397	7754	8822	10606	12657	14438	15060
100	6684	7041	8019	9795	11848	13607	14347
120	6147	6417	7485	9180	11319	13100	13813
140	5704	5954	6945	8518	10502	12155	12817
160	5346	5580	6509	7984	9844	11393	12013

Rotazione oraria  
Clockwise  
rotation  
Uhrzeigersinn

Rotazione antioraria  
Anticlockwise  
rotation  
Gegenuhrzeigersinn

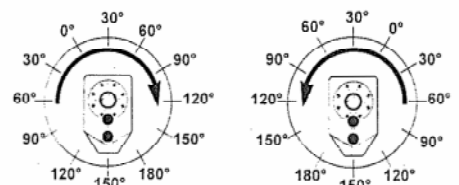

## PD 100/3

### PRESTAZIONI

### PERFORMANCES

### LEISTUNG

## MPD 100/3

n <sub>1</sub>	i	n <sub>2</sub>	M <sub>2</sub> (Nm)	kW <sub>1</sub>	HP <sub>1</sub>	RD
2800	21.40	131	810	12.1	16.4	0.92
	25.68	109	900	11.2	15.2	0.92
	33.16	84	882	8.5	11.5	0.92
	37.74	74	918	7.8	10.5	0.92
	40.44	69	882	7.0	9.5	0.92
	48.74	57	900	5.9	8.0	0.92
	52.70	53	720	4.4	5.9	0.92
	59.44	47	900	4.8	6.6	0.92
	72.91	38	918	4.0	5.5	0.92
	77.47	36	720	3.0	4.0	0.92
	88.91	31	918	3.3	4.5	0.92
	115.88	24	720	2.0	2.7	0.92

n <sub>1</sub>	i	n <sub>2</sub>	M <sub>2</sub> (Nm)	kW <sub>1</sub>	HP <sub>1</sub>	RD	fs	P.A.M.
2800	21.40	131	369	5.5	7.5	0.92	2.19	28/250 - 24/200
	25.68	109	443	5.5	7.5	0.92	2.03	28/250 - 24/200
	33.16	84	572	5.5	7.5	0.92	1.54	28/250 - 24/200
	37.74	74	261	2.2	3.0	0.92	3.52	24/200 - 19/200
	40.44	69	698	5.5	7.5	0.92	1.26	28/250 - 24/200
	48.74	57	336	2.2	3.0	0.92	2.67	24/200 - 19/200
	52.70	53	661	4.0	5.5	0.92	1.09	28/250 - 24/200
	59.44	47	410	2.2	3	0.92	2.19	24/200 - 19/200
	72.91	38	343	1.5	2	0.92	2.68	14/160
	77.47	36	535	2.2	3	0.92	1.35	24/200 - 19/200
	88.91	31	418	1.5	2	0.92	2.19	14/160
	115.88	24	545	1.5	2	0.92	1.32	14/160

n <sub>1</sub>	i	n <sub>2</sub>	M <sub>2</sub> (Nm)	kW <sub>1</sub>	HP <sub>1</sub>	RD
1400	21.40	65	900	6.7	9.1	0.92
	25.68	55	1000	6.2	8.4	0.92
	33.16	42	980	4.7	6.4	0.92
	37.74	37	1020	4.3	5.9	0.92
	40.44	35	980	3.9	5.3	0.92
	48.74	29	1000	3.3	4.4	0.92
	52.70	27	800	2.4	3.3	0.92
	59.44	24	1000	2.7	3.6	0.92
	72.91	19	1020	2.2	3.0	0.92
	77.47	18	800	1.6	2.2	0.92
	88.91	16	1020	1.8	2.5	0.92
	115.88	12	800	1.1	1.5	0.92

n <sub>1</sub>	i	n <sub>2</sub>	M <sub>2</sub> (Nm)	kW <sub>1</sub>	HP <sub>1</sub>	RD	fs	P.A.M.
1400	21.40	65	537	4.0	5.5	0.92	1.68	28/250 - 24/200
	25.68	55	645	4.0	5.5	0.92	1.55	28/250 - 24/200
	33.16	42	832	4.0	5.5	0.92	1.18	28/250 - 24/200
	37.74	37	426	1.8	2.5	0.92	2.39	24/200 - 19/200
	40.44	35	1015	4.0	5.5	0.92	0.97	28/250 - 24/200
	48.74	29	551	1.8	2.5	0.92	1.82	24/200 - 19/200
	52.70	27	728	2.2	3.0	0.92	1.10	28/250 - 24/200
	59.44	24	671	1.8	2.5	0.92	1.49	24/200 - 19/200
	72.91	19	343	0.75	1.0	0.92	2.97	14/160
	77.47	18	729	1.50	2.0	0.92	1.10	24/200 - 19/200
	88.91	16	418	0.75	1.0	0.92	2.44	14/160
	115.88	12	545	0.75	1.0	0.92	1.47	14/160

n <sub>1</sub>	i	n <sub>2</sub>	M <sub>2</sub> (Nm)	kW <sub>1</sub>	HP <sub>1</sub>	RD
900	21.40	42	990	4.7	6.4	0.92
	25.68	35	1100	4.4	6.0	0.92
	33.16	27	1078	3.3	4.5	0.92
	37.74	24	1122	3.0	4.1	0.92
	40.44	22	1078	2.7	3.7	0.92
	48.74	18	1100	2.3	3.1	0.92
	52.70	17	880	1.7	2.3	0.92
	59.44	15	1100	1.9	2.6	0.92
	72.91	12	1122	1.6	2.1	0.92
	77.47	12	880	1.2	1.6	0.92
	88.91	10	1122	1.3	1.8	0.92
	115.88	8	880	0.8	1.1	0.92

n <sub>1</sub>	i	n <sub>2</sub>	M <sub>2</sub> (Nm)	kW <sub>1</sub>	HP <sub>1</sub>	RD	fs	P.A.M.
900	21.40	42	460	2.2	3.0	0.92	2.15	28/250 - 24/200
	25.68	35	552	2.2	3.0	0.92	1.99	28/250 - 24/200
	33.16	27	712	2.2	3.0	0.92	1.51	28/250 - 24/200
	37.74	24	405	1.1	1.5	0.92	2.77	24/200 - 19/200
	40.44	22	869	2.2	3	0.92	1.24	28/250 - 24/200
	48.74	18	523	1.1	1.5	0.92	2.10	24/200 - 19/200
	52.70	17	926	1.8	2.5	0.92	0.95	28/250 - 24/200
	59.44	15	638	1.1	1.5	0.92	1.72	24/200 - 19/200
	72.91	12	391	0.55	0.75	0.92	2.87	14/160
	77.47	12	832	1.1	1.5	0.92	1.06	24/200 - 19/200
	88.91	10	477	0.55	0.75	0.92	2.35	14/160
	115.88	8	622	0.55	0.75	0.92	1.41	14/160

### DIMENSIONI D'INGOMBRO

### OVERALL DIMENSIONS

### ALLGEMEINE ABMESSUNGEN

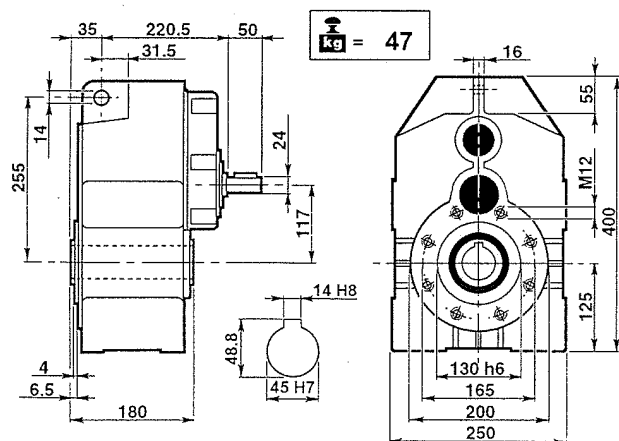

PD 100/3

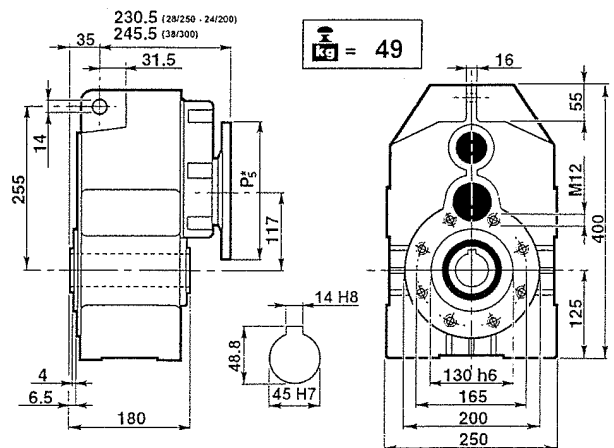

MPD 100/3

P<sub>5</sub>\* : Vedere i PAM per ogni singola versione  
P<sub>5</sub>\* : See PAM size for each single version  
P<sub>5</sub>\* : Siehe PAM Grösse für jede Ausführung



## PD 125

### PRESTAZIONI

### PERFORMANCES

### LEISTUNG

## MPD 125

n <sub>1</sub>	i	n <sub>2</sub>	M <sub>2</sub> (Nm)	kW <sub>1</sub>	HP <sub>1</sub>	RD
2800	10.48	267	1440	42.0	57.1	0.96
	13.49	208	1440	32.6	44.3	0.96
	16.28	172	1440	27.0	36.7	0.96
	16.43	170	1305	24.3	33.0	0.96
	18.60	151	1620	26.6	36.2	0.96
	20.96	134	1530	22.3	30.3	0.96
	25.52	110	1485	17.8	24.2	0.96
	28.90	97	1305	13.8	18.8	0.96
1400	10.48	134	1600	23.3	31.7	0.96
	13.49	104	1600	18.1	24.6	0.96
	16.28	86	1600	15.0	20.4	0.96
	16.43	85	1450	13.5	18.3	0.96
	18.60	75	1800	14.8	20.1	0.96
	20.96	67	1700	12.4	16.8	0.96
	25.52	55	1650	9.9	13.4	0.96
	28.90	48	1450	7.7	10.4	0.96
900	10.48	86	1760	16.5	22.4	0.96
	13.49	67	1760	12.8	17.4	0.96
	16.28	55	1760	10.6	14.4	0.96
	16.43	55	1595	9.5	13.0	0.96
	18.60	48	1980	10.5	14.2	0.96
	20.96	43	1870	8.8	11.9	0.96
	25.52	35	1815	7.0	9.5	0.96
	28.90	31	1595	5.4	7.4	0.96

n <sub>1</sub>	i	n <sub>2</sub>	M <sub>2</sub> (Nm)	kW <sub>1</sub>	HP <sub>1</sub>	RD	fs	P.A.M.
2800	10.48	267	635	18.5	25	0.96	2.27	42/350 - 38/300
	13.49	208	817	18.5	25	0.96	1.76	42/350 - 38/300
	16.28	172	986	18.5	25	0.96	1.46	42/350 - 38/300
	16.43	170	995	18.5	25	0.96	1.31	42/350 - 38/300
	18.60	151	1127	18.5	25	0.96	1.44	42/350 - 38/300
	20.96	134	1270	18.5	25	0.96	1.21	42/350 - 38/300
	25.52	110	1253	15	20	0.96	1.18	42/350 - 38/300
	28.90	97	1041	11	15	0.96	1.25	42/350 - 38/300
1400	10.48	134	1029	15	20	0.96	1.55	42/350 - 38/300
	13.49	104	1325	15	20	0.96	1.21	42/350 - 38/300
	16.28	86	1599	15	20	0.96	1.00	42/350 - 38/300
	16.43	85	1184	11	15	0.96	1.23	42/350 - 38/300
	18.60	75	1827	15	20	0.96	0.99	42/350 - 38/300
	20.96	67	1510	11	15	0.96	1.13	42/350 - 38/300
	25.52	55	1537	9.2	12.5	0.96	1.07	42/350 - 38/300
	28.90	48	1419	7.5	10	0.96	1.02	42/350 - 38/300
900	10.48	86	1174	11	15	0.96	1.50	42/350 - 38/300
	13.49	67	1512	11	15	0.96	1.16	42/350 - 38/300
	16.28	55	1824	11	15	0.96	0.96	42/350 - 38/300
	16.43	55	1255	7.5	10	0.96	1.27	42/350 - 38/300
	18.60	48	2084	11	15	0.96	0.95	42/350 - 38/300
	20.96	43	1601	7.5	10	0.96	1.17	42/350 - 38/300
	25.52	35	1430	5.5	7.5	0.96	1.27	42/350 - 38/300
	28.90	31	1619	5.5	7.5	0.96	0.99	42/350 - 38/300

### DIMENSIONI D'INGOMBRO

### OVERALL DIMENSIONS

### ALLGEMEINE ABMESSUNGEN

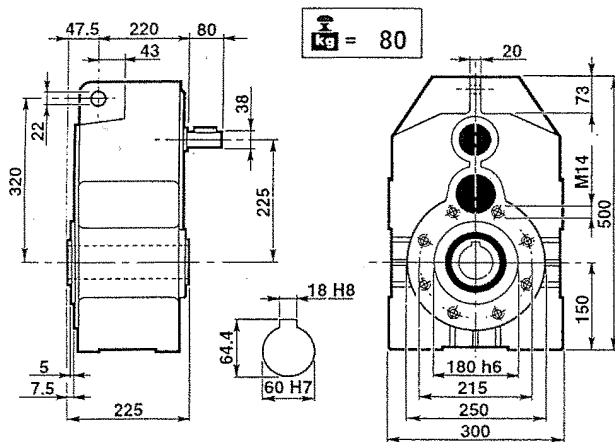

PD 125

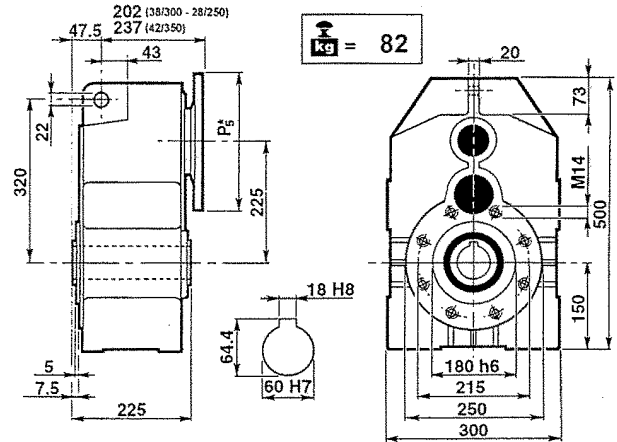

MPD 125

P<sub>5</sub>\* : Vedere i PAM per ogni singola versione  
P<sub>5</sub>\* : See PAM size for each single version  
P<sub>5</sub>\* : Siehe PAM Grösse für jede Ausführung

### CARICHI RADIALI (N)

### OVERHUNG LOADS (N)

### RADIALE BELASTUNGEN (N)

ALBERO VELOCE / INPUT SHAFT / EINGANGSWELLE		
1400 min <sup>-1</sup>	PD 125	PD 125/3
	2100	1600

ALBERO LENTO / OUTPUT SHAFT / ABTRIEBSWELLE							
PD 125 - PD 125/3							
min <sup>-1</sup>	0°	30°	60°	90°	120°	150°	180°
20	18837	19474	21133	23681	26607	28896	29799
40	14245	14889	16415	18963	21896	24310	25211
60	12096	12604	14133	16678	19607	22022	23041
80	10567	11078	12604	15152	18081	20626	21515
100	9548	10059	11456	13993	16926	19439	20496
120	8782	9167	10693	13115	16170	18715	19733
140	8148	8505	9921	12168	15003	17364	18309
160	7637	7972	9299	11405	14063	16275	17161

Rotazione oraria  
Clockwise  
rotation  
Uhrzeigersinn

Rotazione antioraria  
Anticlockwise  
rotation  
Gegenuhrzeigersinn

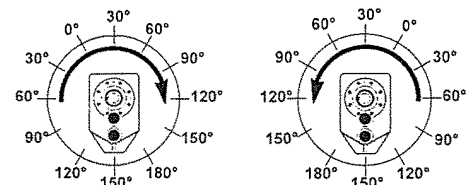

## PD 125/3

### PRESTAZIONI

### PERFORMANCES

### LEISTUNG

## MPD 125/3

n <sub>1</sub>	i	n <sub>2</sub>	M <sub>2</sub> (Nm)	kW <sub>1</sub>	HP <sub>1</sub>	RD
----------------	---	----------------	------------------------	-----------------	-----------------	----

n <sub>1</sub>	i	n <sub>2</sub>	M <sub>2</sub> (Nm)	kW <sub>1</sub>	HP <sub>1</sub>	RD	fs	P.A.M.
----------------	---	----------------	------------------------	-----------------	-----------------	----	----	--------

2800	26.47	106	1890	22.8	30.9	0.92
	30.32	92	1395	14.7	19.9	0.92
	34.08	82	1800	16.8	22.9	0.92
	38.46	73	1656	13.7	18.7	0.92
	41.49	67	1620	12.4	16.9	0.92
	47.25	59	1395	9.4	12.8	0.92
	53.11	53	1818	10.9	14.8	0.92
	59.60	47	1890	10.1	13.7	0.92
	64.66	43	1638	8.1	11.0	0.92
	73.22	38	1395	6.1	8.3	0.92
	93.42	30	1665	5.7	7.7	0.92
105.79	26	1395	4.2	5.7	0.92	

2800	26.47	106	914	11	15	0.92	2.07	38/300
	30.32	92	1047	11	15	0.92	1.33	38/300
	34.08	82	1176	11	15	0.92	1.53	38/300
	38.46	73	664	5.5	7.5	0.92	2.49	19/200
	41.49	67	1432	11	15	0.92	1.13	38/300
	47.25	59	815	5.5	7.5	0.92	1.71	28/250
	53.11	53	917	5.5	7.5	0.92	1.98	28/250
	59.60	47	1029	5.5	7.5	0.92	1.84	19/200
	64.66	43	1116	5.5	7.5	0.92	1.47	28/250
	73.22	38	1264	5.5	7.5	0.92	1.10	28/250
	93.42	30	1612	5.5	7.5	0.92	1.03	19/200
105.79	26	1328	4.0	7.5	0.92	1.05	19/200	

1400	26.47	53	2100	12.6	17.2	0.92
	30.32	46	1550	8.1	11.1	0.92
	34.08	41	2000	9.4	12.7	0.92
	38.46	36	1840	7.6	10.4	0.92
	41.49	34	1800	6.9	9.4	0.92
	47.25	30	1550	5.2	7.1	0.92
	53.11	26	2020	6.1	8.2	0.92
	59.60	23	2100	5.6	7.6	0.92
	64.66	22	1820	4.5	6.1	0.92
	73.22	19	1550	3.4	4.6	0.92
	93.42	15	1850	3.2	4.3	0.92
105.79	13	1550	2.3	3.2	0.92	

1400	26.47	53	1827	11	15	0.92	1.15	38/300
	30.32	46	1751	9.2	12.5	0.92	0.89	38/300
	34.08	41	1968	9.2	12.5	0.92	1.02	38/300
	38.46	36	965	4.0	5.5	0.92	1.91	19/200
	41.49	34	1432	5.5	7.48	0.92	1.26	38/300
	47.25	30	1188	4.0	5.5	0.92	1.31	28/250
	53.11	26	1333	4.0	5.5	0.92	1.52	28/250
	59.60	23	1496	4.0	5.5	0.92	1.40	19/200
	64.66	22	1623	4.0	5.5	0.92	1.12	28/250
	73.22	19	1379	3.0	4.0	0.92	1.12	28/250
	93.42	15	1759	3.0	4.0	0.92	1.05	19/200
105.79	13	1461	2.2	3.0	0.92	1.06	19/200	

900	26.47	34	2310	8.9	12.2	0.92
	30.32	30	1705	5.8	7.8	0.92
	34.08	26	2200	6.6	9.0	0.92
	38.46	23	2024	5.4	7.3	0.92
	41.49	22	1980	4.9	6.6	0.92
	47.25	19	1705	3.7	5.0	0.92
	53.11	17	2222	4.3	5.8	0.92
	59.60	15	2310	4.0	5.4	0.92
	64.66	14	2002	3.2	4.3	0.92
	73.22	12	1705	2.4	3.2	0.92
	93.42	10	2035	2.2	3.0	0.92
105.79	9	1705	1.7	2.2	0.92	

900	26.47	34	1421	5.5	7.5	0.92	1.63	38/300
	30.32	30	1628	5.5	7.5	0.92	1.05	38/300
	34.08	26	1830	5.5	7.5	0.92	1.20	38/300
	38.46	23	826	2.2	3.0	0.92	2.45	19/200
	41.49	22	1620	4.0	5.5	0.92	1.22	38/300
	47.25	19	1015	2.2	3	0.92	1.68	28/250
	53.11	17	1141	2.2	3	0.92	1.95	28/250
	59.60	15	1280	2.2	3	0.92	1.80	19/200
	64.66	14	1389	2.2	3	0.92	1.44	28/250
	73.22	12	1573	2.2	3	0.92	1.08	28/250
	93.42	10	2006	2.2	3	0.92	1.01	19/200
105.79	9	1549	1.5	2	0.92	1.10	19/200	

### DIMENSIONI D'INGOMBRO

### OVERALL DIMENSIONS

### ALLGEMEINE ABMESSUNGEN

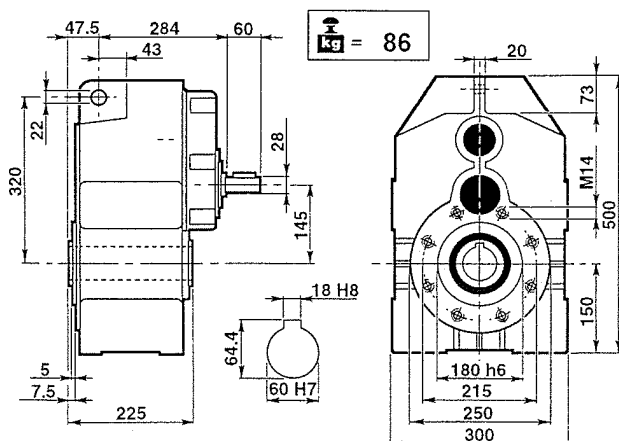

PD 125/3

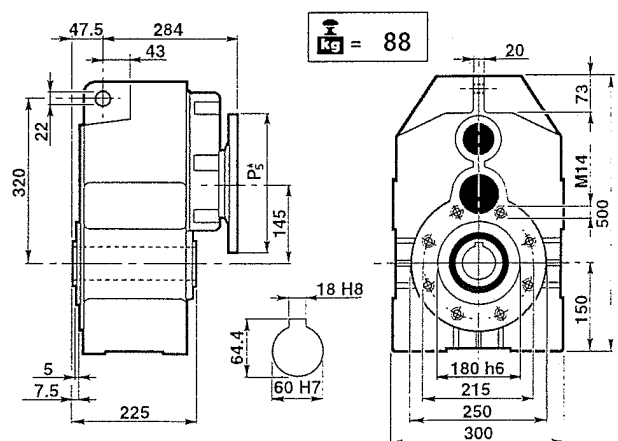

MPD 125/3

P<sub>5</sub>\* : Vedere i PAM per ogni singola versione  
P<sub>5</sub>\* : See PAM size for each single version  
P<sub>5</sub>\* : Siehe PAM Grösse für jede Ausführung

<b>PD 160</b>	PRESTAZIONI	PERFORMANCES	LEISTUNG	<b>MPD 160</b>
---------------	-------------	--------------	----------	----------------

n <sub>1</sub>	i	n <sub>2</sub>	M <sub>2</sub> (Nm)	kW <sub>1</sub>	HP <sub>1</sub>	RD
<b>2800</b>	9.87	284	2700	83.5	113.6	0.96
	12.74	220	2880	69.0	93.9	0.96
	15.54	180	2880	56.6	77.0	0.96
	16.27	172	3150	59.1	80.4	0.96
	19.87	141	2610	40.1	54.6	0.96
	21.01	133	3150	45.8	62.3	0.96
	25.62	109	2880	34.3	46.7	0.96
32.75	85	2700	25.2	34.2	0.96	
<b>1400</b>	9.87	142	3000	46.4	63.1	0.96
	12.74	110	3200	38.4	52.2	0.96
	15.54	90	3200	31.4	42.8	0.96
	16.27	86	3500	32.8	44.7	0.96
	19.87	70	2900	22.3	30.3	0.96
	21.01	67	3500	25.4	34.6	0.96
	25.62	55	3200	19.1	25.9	0.96
32.75	43	3000	14.0	19.0	0.96	
<b>900</b>	9.87	91	3300	32.8	44.6	0.96
	12.74	71	3520	27.1	36.9	0.96
	15.54	58	3520	22.2	30.2	0.96
	16.27	55	3850	23.2	31.6	0.96
	19.87	45	3190	15.8	21.4	0.96
	21.01	43	3850	18.0	24.5	0.96
	25.62	35	3520	13.5	18.3	0.96
32.75	27	3300	9.9	13.5	0.96	

n <sub>1</sub>	i	n <sub>2</sub>	M <sub>2</sub> (Nm)	kW <sub>1</sub>	HP <sub>1</sub>	RD	fs	P.A.M.
<b>2800</b>	9.87	284	808	25	34	0.96	3.34	48/350 - 42/350
	12.74	220	1043	25	34	0.96	2.76	48/350 - 42/350
	15.54	180	1272	25	34	0.96	2.26	48/350 - 42/350
	16.27	172	1332	25	34	0.96	2.37	48/350 - 42/350
	19.87	141	1627	25	34	0.96	1.60	48/350 - 42/350
	21.01	133	1720	25	34	0.96	1.83	48/350 - 42/350
	25.62	109	2097	25	34	0.96	1.37	48/350 - 42/350
32.75	85	2681	25	34	0.96	1.01	48/350 - 42/350	
<b>1400</b>	9.87	142	1422	22	30	0.96	2.11	48/350 - 42/350
	12.74	110	1835	22	30	0.96	1.74	48/350 - 42/350
	15.54	90	2239	22	30	0.96	1.43	48/350 - 42/350
	16.27	86	2344	22	30	0.96	1.49	48/350 - 42/350
	19.87	70	2863	22	30	0.96	1.01	48/350 - 42/350
	21.01	87	3027	22	30	0.96	1.16	48/350 - 42/350
	25.62	55	3104	18.5	25	0.96	1.03	48/350 - 42/350
32.75	43	3217	15	20	0.96	0.93	48/350 - 42/350	
<b>900</b>	9.87	91	1508	15	20	0.96	2.19	48/350 - 42/350
	12.74	71	1947	15	20	0.96	1.81	48/350 - 42/350
	15.54	58	2375	15	20	0.96	1.48	48/350 - 42/350
	16.27	55	2486	15	20	0.96	1.55	48/350 - 42/350
	19.87	45	3036	15	20	0.96	1.05	48/350 - 42/350
	21.01	43	3210	15	20	0.96	1.20	48/350 - 42/350
	25.62	35	2871	11	15	0.96	1.23	48/350 - 42/350
32.75	27	2502	7.5	10	0.96	1.32	48/350 - 42/350	

### DIMENSIONI D'INGOMBRO

### OVERALL DIMENSIONS

### ALLGEMEINE ABMESSUNGEN

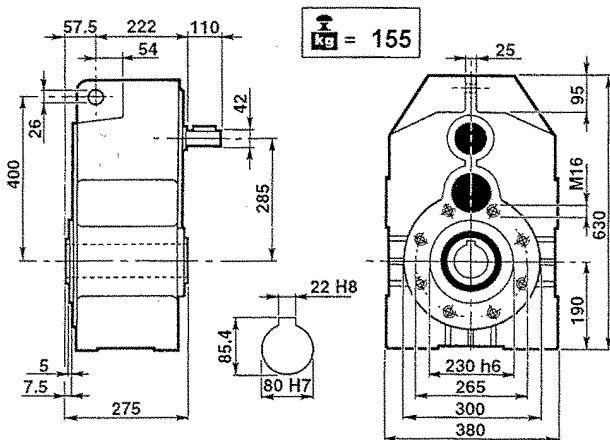

**PD 160**

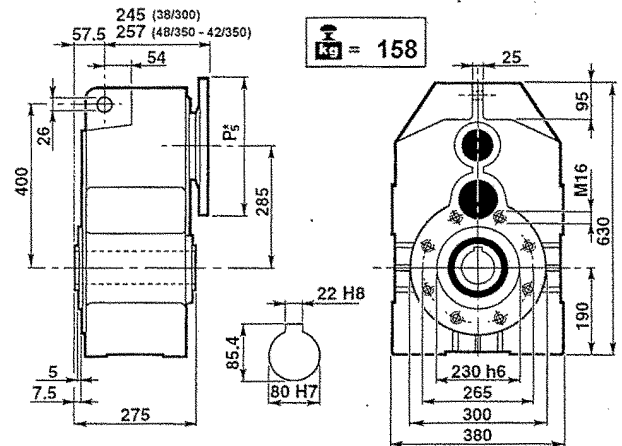

**MPD 160**

P<sub>5</sub>\* : Vedere i PAM per ogni singola versione  
P<sub>5</sub>\* : See PAM size for each single version  
P<sub>5</sub>\* : Siehe PAM Grösse für jede Ausführung

### CARICHI RADIALI (N)

### OVERHUNG LOADS (N)

### RADIALE BELASTUNGEN (N)

ALBERO VELOCE / INPUT SHAFT / EINGANGSWELLE		
	PD 160	PD 160/3
1400 min <sup>-1</sup>	3200	2300

ALBERO LENTO / OUTPUT SHAFT / ABTRIEBSWELLE							
PD 160- PD 160/3							
min <sup>-1</sup>	0°	30°	60°	90°	120°	150°	180°
20	26910	27820	30190	33830	38010	41280	42570
40	20350	21270	23450	27090	31280	34729	36015
60	17280	18005	20190	23825	28010	31460	32915
80	15095	15825	18005	21645	25830	29465	30735
100	13640	14370	16365	19990	24180	27770	29280
120	12545	13095	15275	18735	23100	26735	28190
140	11640	12150	14173	17383	21434	24806	26156
160	10910	11388	13284	16293	20089	23251	24516

Rotazione oraria  
**Clockwise**  
rotation  
Uhrzeigersinn

Rotazione antioraria  
**Anticlockwise**  
rotation  
Gegenuhrzeigersinn

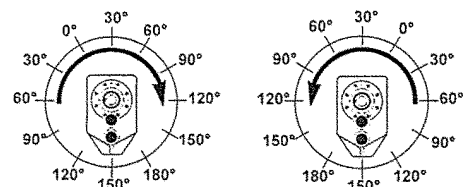

## PD 160/3

### PRESTAZIONI

### PERFORMANCES

### LEISTUNG

## MPD 160/3

n <sub>1</sub>	i	n <sub>2</sub>	M <sub>2</sub> (Nm)	kW <sub>1</sub>	HP <sub>1</sub>	RD
2800	34.24	82	3240	30.2	41.0	0.92
	39.47	71	2988	24.1	32.8	0.92
	41.78	67	3240	24.7	33.6	0.92
	50.46	55	2880	18.2	24.7	0.92
	53.36	52	3258	19.5	26.5	0.92
	58.57	48	3015	16.4	22.3	0.92
	65.07	43	3258	16.0	21.7	0.92
	71.52	39	2880	12.8	17.5	0.92
	75.63	37	3285	13.8	18.8	0.92
	83.19	34	2880	11.0	15.0	0.92
	92.23	30	3285	11.4	15.4	0.92
	117.9	24	2880	7.8	10.6	0.92

n <sub>1</sub>	i	n <sub>2</sub>	M <sub>2</sub> (Nm)	kW <sub>1</sub>	HP <sub>1</sub>	RD	fs	P.A.M.
2800	34.24	82	2686	25	34	0.92	1.21	48/350 - 42/350
	39.47	71	1362	11	15	0.92	2.19	38/300
	41.78	67	3276	25	34	0.92	0.99	48/350 - 42/350
	50.46	55	1742	11	15	0.92	1.65	38/300
	53.36	52	1842	11	15	0.92	1.77	38/300
	58.57	48	1011	5.5	7.5	0.92	2.98	28/250
	65.07	43	2246	11	15	0.92	1.45	38/300
	71.52	39	1234	5.5	7.5	0.92	2.33	28/250
	75.63	37	1305	5.5	7.5	0.92	2.52	28/250
	83.19	34	2871	11	15	0.92	1.00	38/300
	92.23	30	1592	5.5	7.5	0.92	2.06	28/250
	117.9	24	2035	5.5	7.5	0.92	1.42	28/250

1400	34.24	41	3600	16.8	22.8	0.92
	39.47	35	3320	13.4	18.2	0.92
	41.78	34	3600	13.7	18.7	0.92
	50.46	28	3200	10.1	13.7	0.92
	53.36	26	3620	10.8	14.7	0.92
	58.57	24	3350	9.1	12.4	0.92
	65.07	22	3620	8.9	12.1	0.92
	71.52	20	3200	7.1	9.7	0.92
	75.63	19	3650	7.7	10.5	0.92
	83.19	17	3200	6.1	8.3	0.92
	92.23	15	3650	6.3	8.6	0.92
	117.9	12	3200	4.3	5.9	0.92

1400	34.24	41	3223	15	20	0.92	1.12	48/350 - 42/350
	39.47	35	2725	11	15	0.92	1.22	38/300
	41.78	34	3931	15	20	0.92	0.92	48/350 - 42/350
	50.46	28	2913	9.2	12.5	0.92	1.10	38/300
	53.36	26	3081	9.2	12.5	0.92	1.18	38/300
	58.57	24	1470	4.0	5.5	0.92	2.28	28/250
	65.07	22	3063	7.5	10	0.92	1.18	38/300
	71.52	20	1795	4.0	5.5	0.92	1.78	28/250
	75.63	19	1899	4.0	5.5	0.92	1.92	28/250
	83.19	17	2871	5.5	7.5	0.92	1.11	38/300
	92.23	15	2315	4.0	5.5	0.92	1.58	28/250
	117.9	12	2960	4.0	5.5	0.92	1.08	28/250

900	34.24	26	3960	11.8	16.1	0.92
	39.47	23	3652	9.5	12.9	0.92
	41.78	22	3960	9.7	13.2	0.92
	50.46	18	3520	7.1	9.7	0.92
	53.36	17	3982	7.6	10.4	0.92
	58.57	15	3685	6.4	8.8	0.92
	65.07	14	3982	6.3	8.5	0.92
	71.52	13	3520	5.0	6.9	0.92
	75.63	12	4015	5.4	7.4	0.92
	83.19	11	3520	4.3	5.9	0.92
	92.23	10	4015	4.5	6.1	0.92
	117.9	8	3520	3.1	4.2	0.92

900	34.24	26	3677	11	15	0.92	1.08	48/350 - 42/350
	39.47	23	2119	5.5	7.5	0.92	1.72	38/300
	41.78	22	3058	7.5	10	0.92	1.30	48/350 - 42/350
	50.46	18	2709	5.5	7.5	0.92	1.30	38/300
	53.36	17	2865	5.5	7.5	0.92	1.39	38/300
	58.57	15	1258	2.2	3.0	0.92	2.93	28/250
	65.07	14	3494	5.50	7.5	0.92	1.14	38/300
	71.52	13	1536	2.2	3.0	0.92	2.29	28/250
	75.63	12	1624	2.2	3.0	0.92	2.47	28/250
	83.19	11	3248	4.0	5.5	0.92	1.08	38/300
	92.23	10	1981	2.2	3.0	0.92	2.03	28/250
	117.9	8	2532	2.2	3.0	0.92	1.39	28/250

### DIMENSIONI D'INGOMBRO

### OVERALL DIMENSIONS

### ALLGEMEINE ABMESSUNGEN

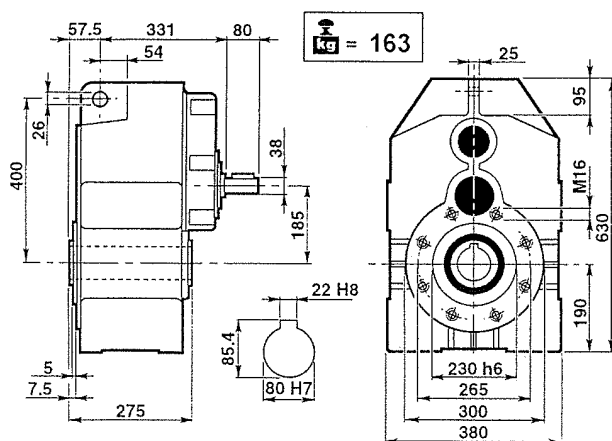

PD 160/3

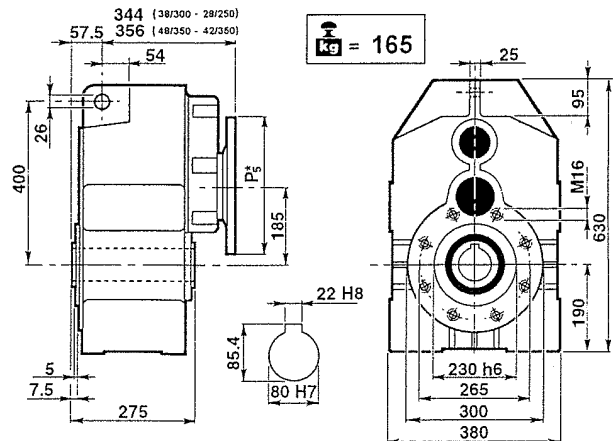

MPD 160/3

P<sub>5</sub>\* : Vedere i PAM per ogni singola versione  
P<sub>5</sub>\* : See PAM size for each single version  
P<sub>5</sub>\* : Siehe PAM Grösse für jede Ausführung

## ACCESSORI

### FLANGE IN USCITA

Tutti i riduttori delle serie PL, PD possono essere equipaggiati, su richiesta, con flange in uscita di dimensioni unificate (flange B5). Si è optato per la forma quadrata sulle grandezze 63 - 80 - 100 e per la forma circolare sulle grandezze 125 e 160. Si assume come standard la posizione destra guardando il riduttore dal lato dell'entrata nella posizione di montaggio B3.

## ACCESSORIES

### OUTPUT FLANGES

All PL and PD gearboxes can be equipped, upon request, with output B5 flanges. Square flanges have been provided on sizes 63 - 80 - 100 and round flanges are available on sizes 125 - 160. Standard position is on the right looking at the gearbox from input side in mounting position B3.

## ZUBEHÖR

### ABTRIEBSFLANSCH

Auf Anfrage können alle PL - PD Getriebe mit einem genormten Abtriebsflansch (B5) geliefert werden. Für die Getriebe 63 - 80 und 100 sind rechteckige, für die Getriebe 125 und 160 sind runde Flansche vorgesehen. In der Standardausführung liegt der Flansch bei der Einbaulage B3 (Eingangswelle unten, Abtriebswelle oben) auf die Eingangswelle gesehen rechts.

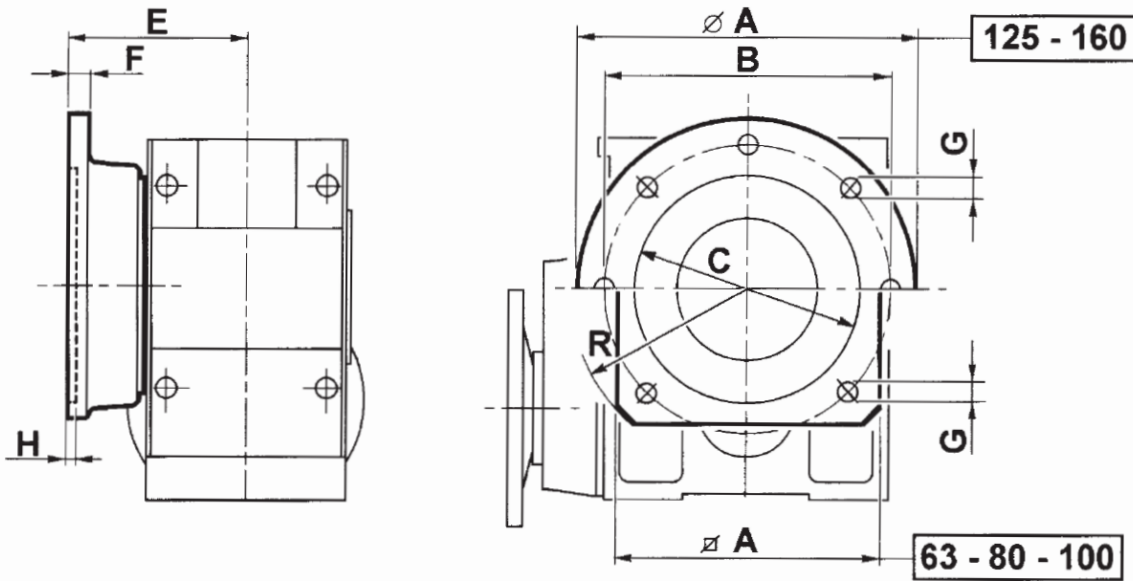

	○ A	□ A	B	C	E	F	G	H	R
<b>63</b>	-	150	165	130	113	12	4x11	5	100
<b>80</b>	-	190	215	180	132.5	14	4x14	6	125
<b>100</b>	-	240	265	230	150.5	16	4x16	5	150
<b>125</b>	350	-	300	250	174	18	8x16	6	-
<b>160</b>	450	-	400	350	195	20	8x18	7	-

## ALBERI LENTI

Tutti i riduttori delle serie PL e PD possono essere equipaggiati, su richiesta, con alberi lenti semplici o con alberi lenti doppi.

Per l'albero lento semplice è realizzata la versione con spallamento, mentre sul lato opposto all'uscita della parte sporgente, il canotto è chiuso da apposita rondella.

L'albero lento doppio è invece realizzato, per semplicità costruttiva, con unico diametro, restando la funzione di spallamento affidata all'organo utilizzatore che sarà fissato alle estremità libere dell'albero.

## OUTPUT SHAFTS

All PL and PD gearboxes can be equipped, on request, with single or double output shafts.

The single output shaft is accomplished in the version with shoulder, while on the opposite side the hollow shaft is closed by a suitable washer.

The double output shaft is, on the contrary, accomplished with a single diameter, for ease of manufacture. The function of shouldering is developed by the connection piece which will be placed on the free shaft ends.

## STECKWELLEN

Alle PL und PD Getriebe können, auf Anfrage, mit einseitiger oder doppelseitiger Steckwelle ausgerüstet werden.

Die einseitige Ausführung ist mit einer Schulter ausgeführt, und die Hohlwelle ist bei einer Scheibe auf der gegenüberliegenden Seite geschlossen.

Die doppelseitige Steckwelle ist, für eine einfacheren Bau, mit individuellem Durchmesser ausgeführt, und die Schulterfunktion ist direkt von dem zusammenpassenden Maschinenteil entwickelt.

Albero lento semplice  
Single output shaft  
Einseitige Steckwelle

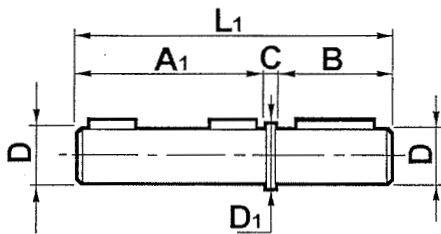

	D	B	D1	A1	C	L1
56	25	50	30	115	5	170
63	30	60	35	125	5	190
80	35	60	40	150	5	215
100	45	90	50	170	8	268
125	60	110	70	210	10	330
160	80	140	90	255	15	410

Albero lento doppio  
Double output shaft  
Doppelseitige Steckwelle

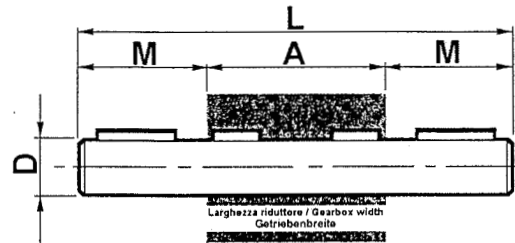

	D	A	L	M
56	25	120	220	50
63	30	135	255	60
80	35	160	280	60
100	45	180	360	90
125	60	225	445	110
160	80	275	555	140

## BRACCI DI REAZIONE PER RIDUTTORI PENDOLARI

## TORQUE ARMS FOR SHAFT MOUNTED

## DREHMOMENTSTÜTZEN FÜR FLACHGETRIEBE

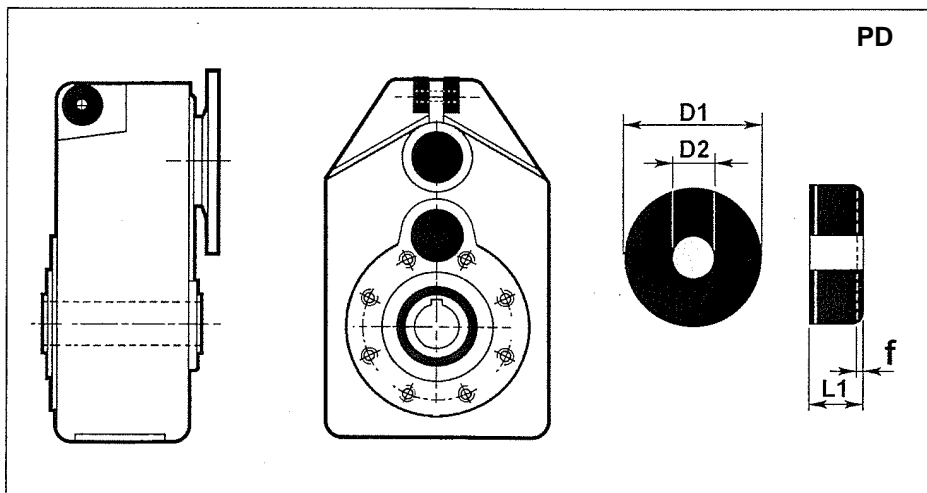

	63	80	100	125	160
D1	30	40	40	60	80
L1	15	20	20	30	40
D2	11	12.5	12.5	21	25
f min	-	1.5	1.5	3	3.7
f max	-	2.3	2.3	4	6



## DISPOSITIVO ANTIRETRO

A richiesta, è possibile fornire i riduttori PL e PD provvisti di dispositivo antiretro, per evitare il moto retrogrado, ovvero il fatto che il riduttore possa essere azionato attraverso l'albero lento dal carico resistente divenuto carico motore. L'antiretro è provvisto per l'installazione sulla seconda sporgenza dell'albero veloce. I cuscinetti antiretro sono stati ampiamente dimensionati in funzione della massima coppia permessa da ogni riduttore, e pertanto ne è consentito l'impiego con qualsiasi rapporto di riduzione, anche particolarmente veloce. Dovrà essere sempre precisato in fase d'ordine per quale senso di rotazione deve essere consentita la rotazione libera.

## BACKSTOP DEVICE

**On request it is possible to have backstop mounted on the PL and PD line. Purpose of the backstop is to prevent the reversible motion, that is the fact that the gearbox might be operated through the output shaft by the resisting load so becoming driving load. The backstop device can be applied to the second end of the fast shaft. The irreversible bearing have been largely oversized according to the maximum torque allowed by each gearbox so that backstop devices are suitable for any reduction ratio. The direction of free rotation must be specified when the order is placed.**

## RÜCKLAUFSPERRE

*Die Rücklaufsperrre ist eine Einrichtung im Getriebe, um die Anlage nach dem Abschalten des Motors am Rückwärtslauf zu hindern. Wie in dem Ausschnitt ersichtlich, ist die Anbringung der Rücklaufsperrre an der gegenüberliegenden Seite der Eingangswelle vorgesehen. Die Rücklaufsperrre ist für den Einbau auf den zweiten Absatz der Antriebswelle vorgesehen. Die Rücklaufsperrre ist ausreichend dimensioniert und kann an jedem Getriebe sowohl mit hohen als auch mit niedrigen Untersetzungen angebaut werden. Bei Bestellung muß der Drehsinn stets angegeben werden.*

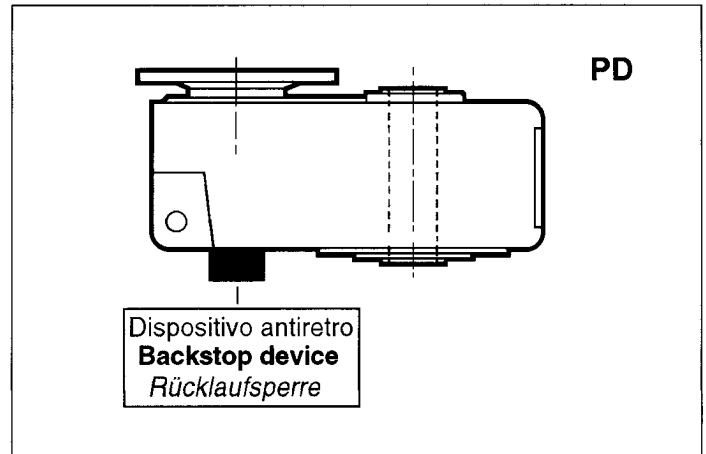
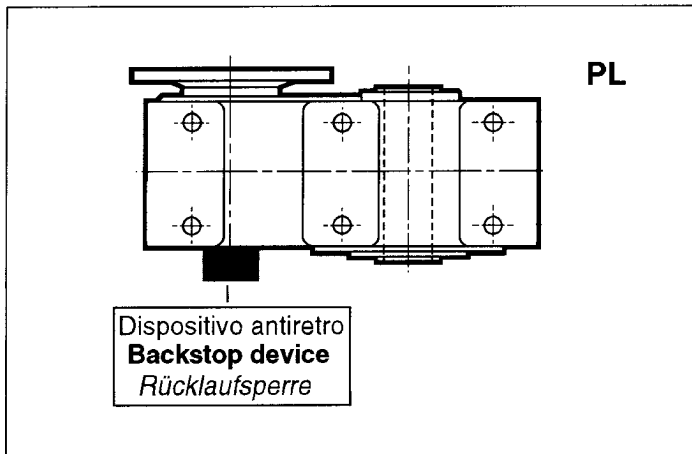

## PARTI DI RICAMBIO

Per consultare il catalogo ricambi rivolgersi all'Ufficio Tecnico della SITI S.p.a. e richiedere la documentazione cartacea o il CD-ROM interattivo.

## SPARE PARTS

To consult the spare parts catalogue, contact the SITI S.p.a. engineering office and request a hard copy of the documentation or the interactive CD-ROM.

## ERSATZTEILE

Für den Ersatzteilkatalog wenden Sie sich bitte an die Technische Abteilung der Firma SITI S.p.a.; dort erhalten Sie die Dokumentation auf Papier oder die interaktive CD-ROM.

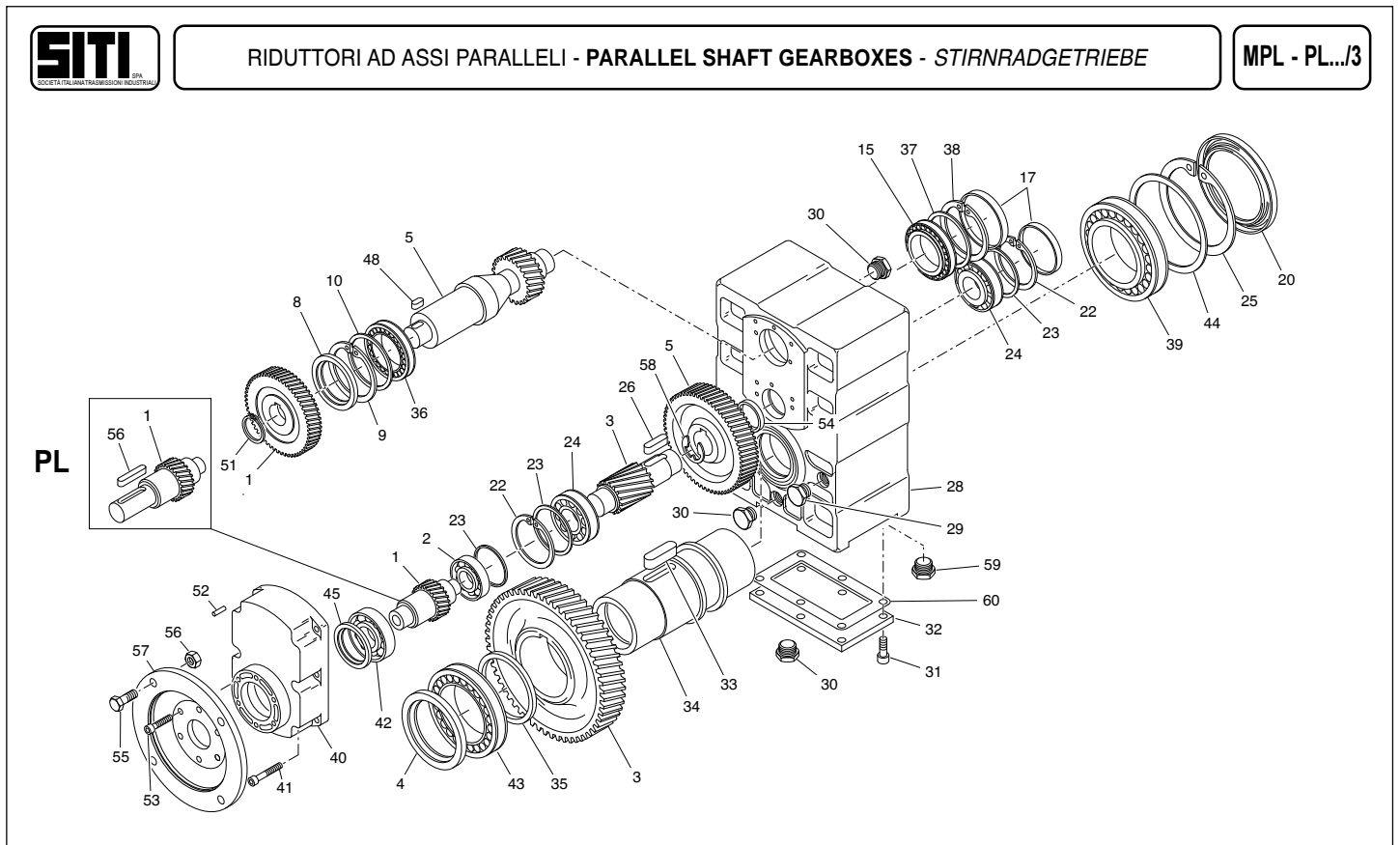
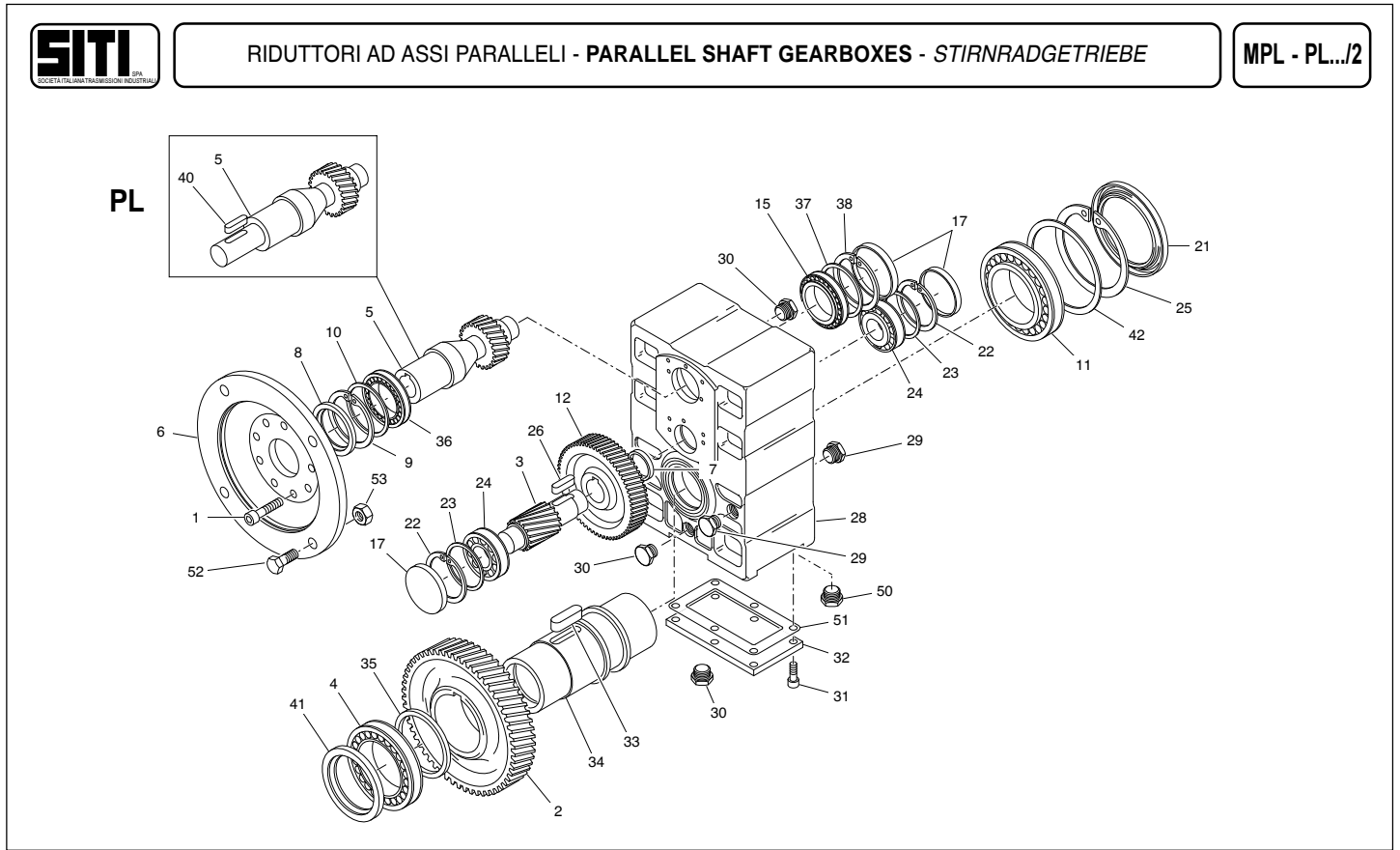

PD

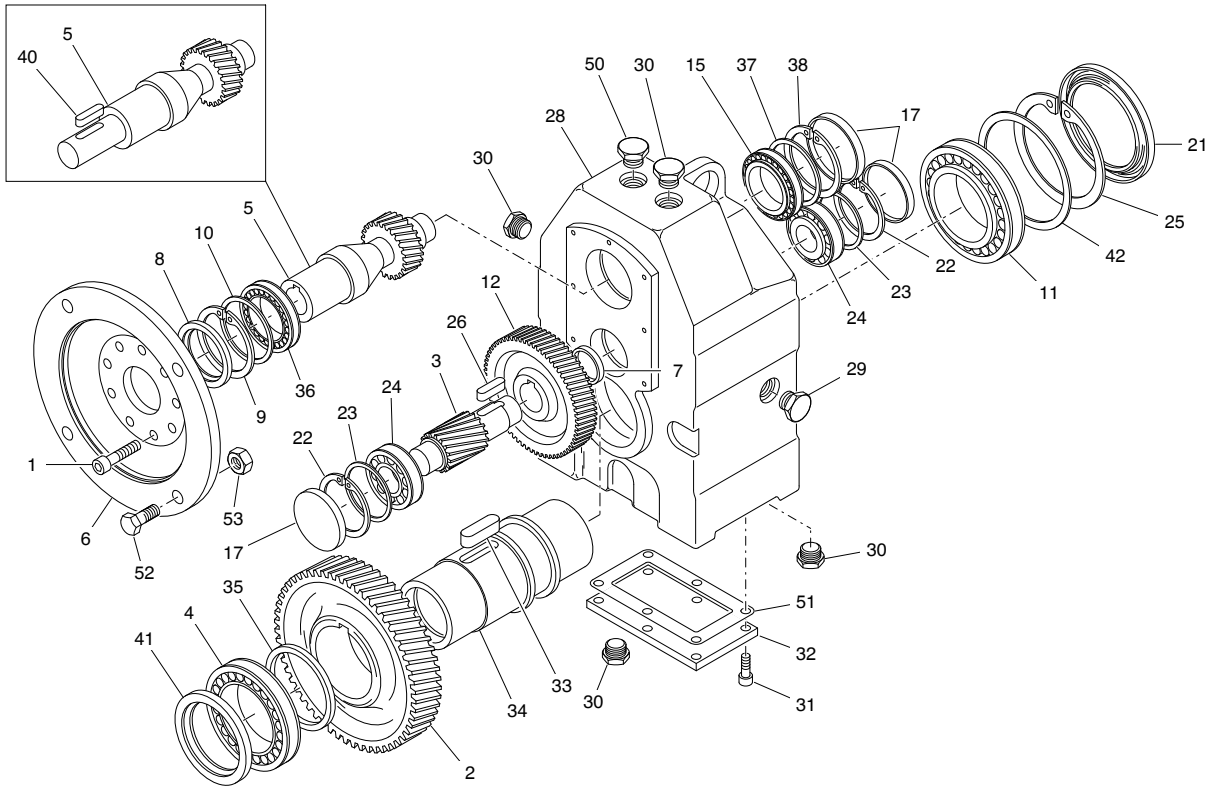

PD

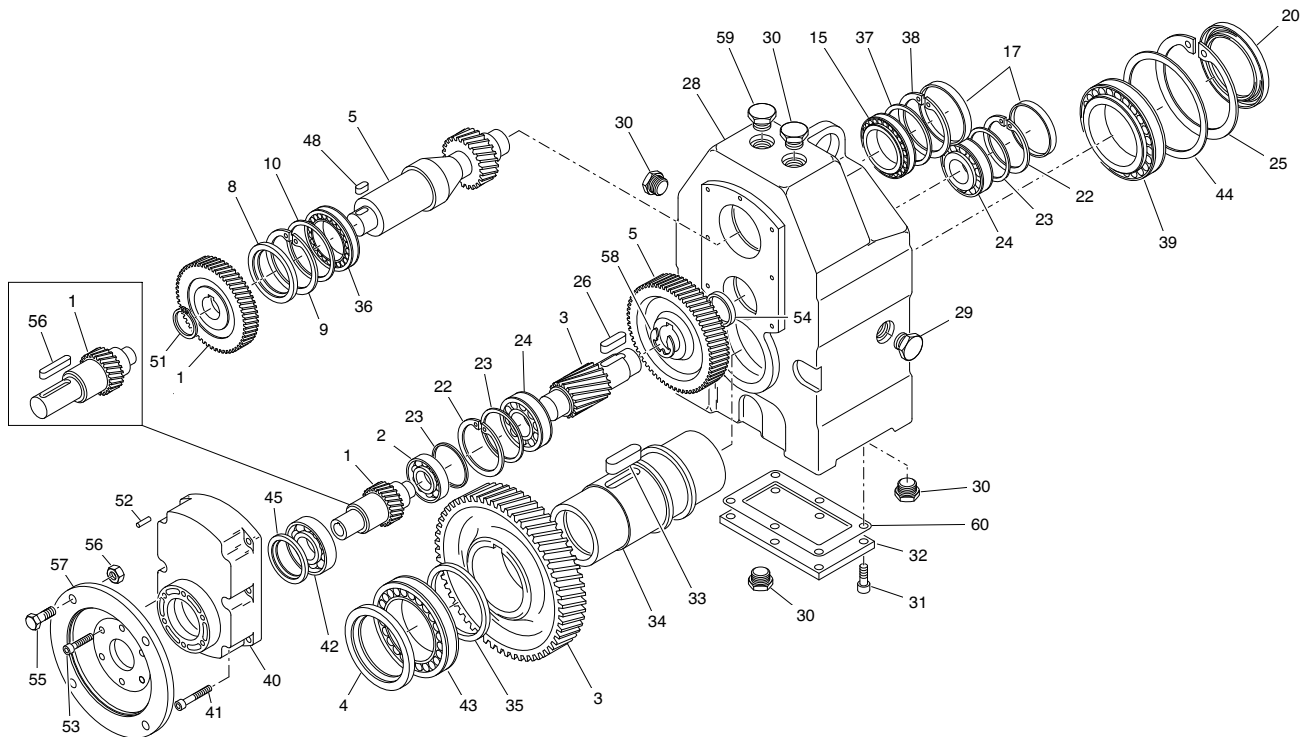

CONDIZIONI GENERALI DI VENDITA

1) **GARANZIA** - La ns. garanzia ha la durata di anni uno dalla data di fatturazione del prodotto. Essa è limitata esclusivamente alla riparazione o alla sostituzione gratuita dei pezzi da noi riconosciuti come difettosi ed il reclamo non potrà mai dar luogo all'annullamento od alla riduzione delle ordinazioni da parte del committente e tanto meno alla corresponsione di indennizzi di sorta da parte ns. Il materiale da riparare in garanzia o comunque soggetto ad anomalie, sarà da noi ritirato solo se ci perverrà in porto franco e sarà reso al cliente in porto assegnato. La ns. garanzia decade se i pezzi resi come difettosi sono stati comunque manomessi o riparati. Per manomissione si intende anche l'applicazione del motore fuori dall'ambito e dalla sede della ns. Società. La ns. garanzia non copre danni o difetti dovuti ad agenti esterni, deficienza di manutenzione, sovraccarico, lubrificante inadatto, scelta inesatta del tipo, errore di montaggio e danni derivanti in seguito a trasporto da parte del committente o trasportatore designato, essendo la spedizione sempre a spese e rischio del committente.

2) **TRASPORTO** - Ad ogni effetto, anche di legge, la merce si ritiene accettata dal cliente (e consegnata) all'uscita dalla ns. sede o magazzini. Il trasporto della merce si intende sempre per conto, rischio e pericolo dell'acquirente anche se la merce è venduta franco destino e se il trasporto viene effettuato con mezzi della ditta venditrice e condotti da persona incaricata dalla medesima.

3) **PREZZI** - La ns. Società si riserva di modificare in qualsiasi momento le proprie quotazioni (anche se confermate) se ciò si rendesse necessario in conseguenza a mutevoli condizioni di mercato o di produzione. Il listino prezzi si riferisce a merce franco ns. stabilimento, escluso imballo ed ogni eventuale altra spesa.

4) **RECLAMI** - È convenuto espressamente che eventuali reclami o contestazioni da farsi, a pena di nullità; sempre in forma scritta ed entro i termini di legge non danno comunque diritto all'acquirente di sospendere o ritardare i pagamenti. Non si accettano addebiti per risarcimento di danni a cose e persone o ritardi di consegna. Se entro 8 gg. Dal ricevimento della ns. conferma d'ordine non ci perverrà alcuna contestazione, la stessa si intenderà accettata in tutte le sue parti.

5) **INTERESSI** - Resta espressamente convenuto che gli interessi verranno fissati ed accettati, in ogni sede di ritardato pagamento, secondo le condizioni medie di tasso applicato dagli Istituti Bancari alla Società venditrice in quel momento.

6) **RISERVA DI PROPRIETÀ** - La merce viene venduta con riserva di proprietà finché non sarà effettuato il pagamento dell'intero prezzo, di eventuali interessi e accessori. Il rilascio di cambiali ed eventuali loro rinnovi, anche parziali, non potranno considerarsi quale novazione né quale pagamento definitivo del prezzo, se non a buon fine delle stesse, né potranno comunque pregiudicare la riserva di proprietà.

7) **FORO COMPETENTE** - Si accetta espressamente che qualsiasi controversia, comunque nascente o discendente dalla vendita deve essere rimessa, anche in via derogativa, al giudice dell'Autorità Giudiziaria di Bologna, quale unico Foro competente; ma la ditta venditrice potrà anche adire, a sua scelta, l'autorità giudiziaria del luogo, della residenza o domicilio dell'acquirente ovvero del luogo ove si trova l'oggetto della fornitura.

8) **RESI - NON SI ACCETTANO RESTITUZIONI DI MATERIALI** se non precedentemente autorizzato per iscritto dalla ns. Società.

9) **LISTINO** - Il listino attualmente in vigore annulla e sostituisce tutti i precedenti.

TERMS AND CONDITIONS OF SALE

1) **GUARANTEE** - Our guarantee expires after one year from invoice date of the product. It only covers the replacement or repair free of charge of the defective units or parts provided that we admit that said faults or defects are to be ascribed to manufacturing processes. The customer does not have to feel entitled to cancel or reduce the outstanding orders because of defective material previously supplied. We will not be responsible for the payment of any charges related to goods to be replaced or repaired under guarantee. Returns of material will only be accepted if both back and forth transport charges will be covered by the customer. Our guarantee becomes completely null and void if units result altered or repaired. For alteration it is included also the application of the motor out of the ambit and circle of our Society. Our guarantee does not cover defects or faults which would be attributed to external factors, insufficient maintenance, overload, inadequate lubrication, improper selection, mounting errors or shipping damages being shipment risks and expenses on behalf of the customer.

2) **SHIPMENT** - Material is considered accepted by the customer once it leaves our warehouse: Shipment of goods is considered at buyer's risk even if shipment is effected free domicile of customer or through shipper's means of transports or forwarding agents appointed by the shipper.

3) **PRICES** - Our Company reserve the right to modify their own quotation (although confirmed) if it is necessary because of the unconstant conditions of market and production. The price list refers to ex-works prices. Not including packing and any other additional costs.

4) **COMPLAINTS** - Complaints for defective material must be effected in writing and within the legal terms or they will be considered null. In case of complaints the buyer is not anyhow entitled to stop or delay payments. Debit notes for refunds of damages to objects or persons as well as deliveries are not accepted. Any claims should be notified within 8 days from receipt of our order confirmation, otherwise it will be considered as accepted in all its parts.

5) **INTERESTS** - It is understood that interests have to be agreed and accepted, in occasion of late payments, according to the current average terms, applied by the Shipper's blanks.

6) **CONDITIONAL SALES** - We reserve the right of property on goods sold until the whole payment has been effected together with the settlement of eventual interests and accessoires. The grant of a bill or its eventual renewal cannot be considered as a definitive payment of the price and will be subjected to collection.

7) **PLACE OF JURISDICTION** - All disputes which may arise in relation to the sales shall be governed by the Italian Law and the Law Court of Bologna shall have the sole jurisdiction. The supplier reserve the right to choose, as place of jurisdiction, the purchaser's place of residence being the final destination of goods supplied.

8) **NO RETURNS OF MATERIAL WILL BE ACCEPTED unless previously authorised in writing from our Society.**

9) **PRICE LIST** - This current price list cancels and replaces all the previous ones.

ALLGEMEINE VERKAUFSBEDINGUNGEN

1) **GARANTIE** - Wir gewähren eine Garantie von einem Jahr ab dem Rechnungsdatum des Produkts. Sie beschränkt sich ausschließlich auf die irgendetwelche Reparatur bzw. den kostenlosen Ersatz der von uns als defekt anerkannten Teile. Bei Reklamation entsteht dem Käufer kein Recht auf Stornierung bzw. Reduzierung der Aufträge und ebenso kein Anspruch auf die irgendetwelche Entschädigungen unsererseits. Die Rücknahme in Garantie des zu reparierenden bzw. defekten Materials erfolgt nur, wenn uns die Ware frachtfrei zurückgesendet wird. Der Kunde erhält das Material dann per Nachnahme zurück. Der Garantieanspruch verfällt, wenn die als defekt zurückgesandten Teile manipuliert oder repariert wurden. Unter Manipulation versteht man auch die Montage des Motors außerhalb unseres Werks. Unsere Garantie deckt keine Schäden oder Defekte in Folge von äußeren Einflüssen, Wartungsmängeln, Überlastungen, ungeeigneten Schmierstoffen, Fehlern bei Wahl des Typs, Montagefehlern und Transportschäden, die durch den Auftraggeber oder den von diesem beauftragten Transporteur verursacht werden, da der Versand stets auf Kosten und Gefahr des Auftraggebers erfolgt.

2) **TRANSPORT** - Die Ware versteht sich in jeder Hinsicht – auch rechtmäßig – bei Verlassen unseres Werks oder unserer Lager als vom Kunden angenommen (ausgeliefert). Der Transport der Ware geht steht zu Lasten und Gefahr des Käufers, auch bei Verkauf der Ware mit der Klausel "frei Bestimmungsort" und auch bei Auslieferung mit Transportmitteln und Transportführern des Verkäufers.

3) **PREISE** - Unsere Firma behält sich das Recht vor, ihre Preise (auch wenn bestätigt) jederzeit zu ändern, wenn dies in Folge von Schwankungen der Markt- und Produktionslage erforderlich sein sollte. Die Preisliste bezieht sich auf Ware ab unser Werk exklusive Verpackung oder sonstige Kosten.

4) **REKLAMATIONEN** - Eventuelle Reklamationen oder Beanstandungen werden nur akzeptiert, wenn sie in schriftlicher Form und innerhalb der gesetzlich vorgesehenen Fristen erfolgen. Der Käufer kann daraus nicht das Recht ableiten, die Zahlungen einzustellen oder zu verschieben. Anlastungen von Entschädigungen aufgrund von Personen- und Sachschäden oder Lieferverzögerungen werden nicht akzeptiert. Wenn innerhalb von 8 Tagen ab Erhalt unserer Auftragsbestätigung keine Reklamation eingeht, gilt die Lieferung in all ihren Teilen als angenommen.

5) **ZINSEN** - Es gilt als ausdrücklich vereinbart, dass die Zinsen bei jedem Zahlungsverzug entsprechend den durchschnittlichen Konditionen des Zinssatzes festgesetzt und akzeptiert werden, den die Bankinstitute zu diesem Zeitpunkt dem Verkäufer gewähren.

6) **EIGENTUMSVORBEHALT** - Die Ware steht bis zur Zahlung des gesamten Kaufpreises nebst eventueller Zinsen und Nebenkosten unter Eigentumsvorbehalt. Die Ausstellung von Wechseln und eventuelle, auch teilweise Verlängerungen dürfen weder als Novation noch als endgültige Zahlung des Kaufpreises, außer bei effektiver Einlösung, angesehen werden, noch gilt dadurch der Eigentumsvorbehalt als beseitigt.

7) **GERICHTSSTAND** - Es gilt als ausdrücklich angenommen, dass alle Rechtstreitigkeiten aus oder im Zusammenhang mit diesem Verkaufsgeschäft, auch derogatorisch, an die Justizbehörde Bologna als alleinigen Gerichtsstand verwiesen werden. Der Verkäufer kann jedoch nach eigener Wahl die Gerichtsbehörde am Ort bzw. Wohnsitz des Käufers bzw. am Ort, wo sich der Liefergegenstand befindet, anrufen.

8) **RÜCKGABEN - RÜCKGABEN VON MATERIALIEN WERDEN NUR ANGENOMMEN**, wenn dafür eine schriftliche Genehmigung unserer Firma erteilt wurde.

9) **PREISLISTE** - Die derzeit gültige Preisliste annulliert und ersetzt alle vorhergehenden.







SOCIETÀ ITALIANA TRASMISSIONI INDUSTRIALI



RIDUTTORI  
MOTORIDUTTORI  
VARIATORI CONTINUI  
MOTORI ELETTRICI C.A./C.C.  
GIUNTI ELASTICI

GEARBOXES  
GEARED MOTORS  
SPEED VARIATORS  
A.C./D.C. ELECTRIC MOTORS  
FLEXIBLE COUPLINGS



**ITALIA (ITALY)**  
**SEDE e STABILIMENTO**  
**HEADQUARTERS**

Via G. Di Vittorio, 4  
40050 Monteveglio - BO - Italy  
Tel. +39/051/6714811  
Fax. +39/051/6714858  
E-mail: [info@sitiriduttori.it](mailto:info@sitiriduttori.it)  
[commitalia@sitiriduttori.it](mailto:commitalia@sitiriduttori.it)  
[export@sitiriduttori.it](mailto:export@sitiriduttori.it)  
WebSite: [www.sitiriduttori.it](http://www.sitiriduttori.it)



**CINA (CHINA)**  
**SEDE e STABILIMENTO**  
**OFFICE AND PLANT**

Shang Hai SITI Power Transmission Co.,Ltd.  
No. 303 Kangliu Road Kangqiao Industrial Zone Pudong  
Shang Hai, P.R. China P.C.: 201315  
Tel. +86-21-68060500  
Fax. +86-21-68122539  
E-mail: [service@sh-siti.com](mailto:service@sh-siti.com)  
WebSite: [www.sh-siti.com](http://www.sh-siti.com)